

COMPRESSOR/CONDENSING UNITS

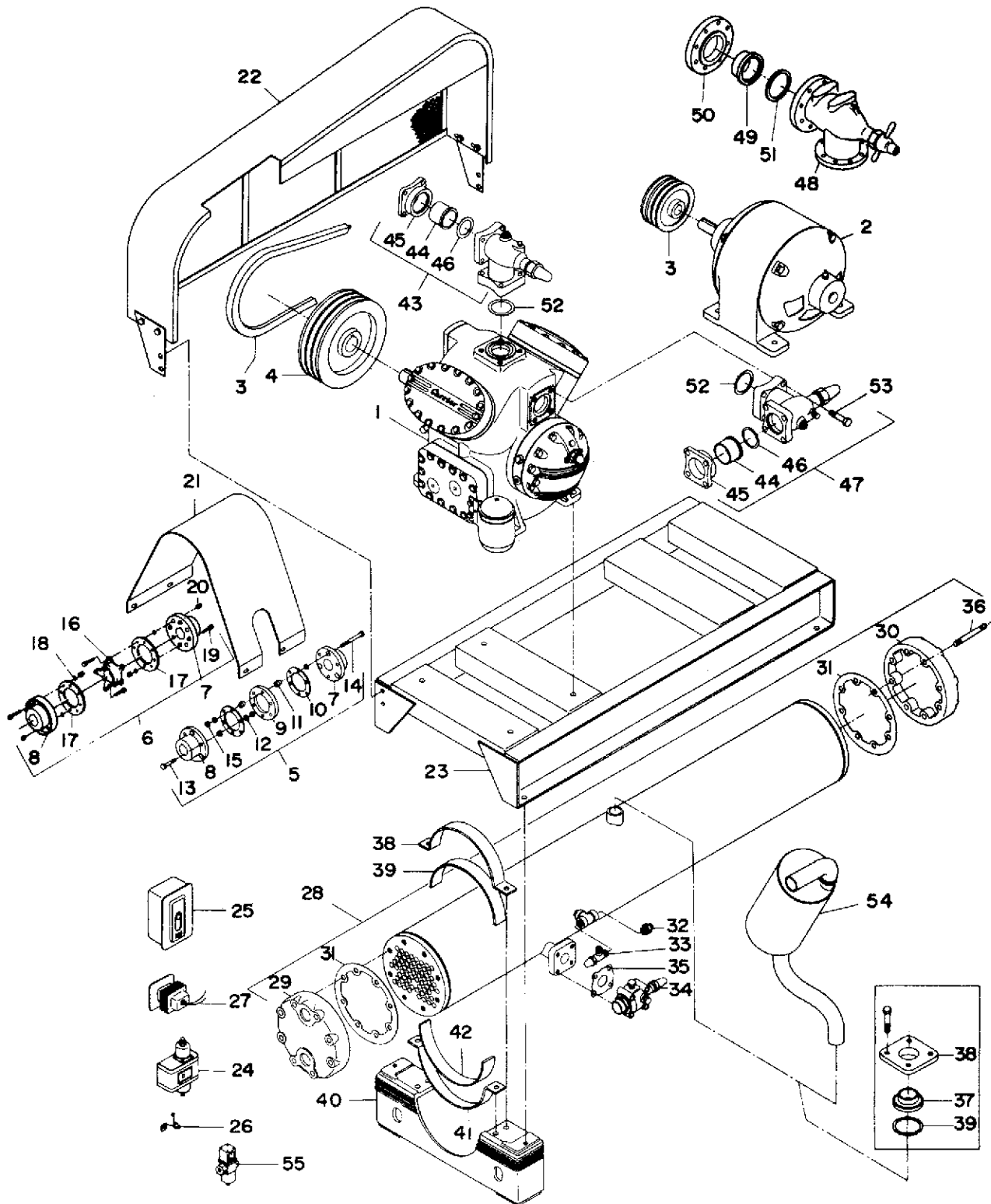



COMPRESSOR/CONDENSING UNITS

5H
FREON

ITEM NO.	PART NAME	LDC	REPLACEMENT PART NUMBER	UNIT USAGE							
				5H							
				40	46	60	66	80	86	120	126

COMPRESSOR GROUP

1	Compressor Assembly		5H40-A219	1								
			5H46-A219		1							
			5H60-A219			1						
			5H66-A219				1					
			5H80-A219					1				
			5H86-A219						1			
			5H120-A219							1		
			5H126-A219								1	

NOTE: Replacement Service Compressors are less Fly Wheel or Coupling, Service Valves, Pressure Switches, Oil Safety Switch and Crankcase Heater, but include Crankcase Heater Casings.

Compressors are also less Oil Pressure Gauges and 5H40-86 is less Oil Filter.

DRIVE GROUP

2	Compressor Motor	CD										
3	Belt Drive Packages Includes: Pulley, Belts and Flywheel	AP										
4	Flywheel Packages											
	11.00 P.D. 3C Grooves	AP	5H40-394									
	11.00 P.D. 5C Grooves	AP	5H60-394									
	17.35 P.D. 5C Grooves	AC	5H61-1104									
	11.00 P.D. 6C Grooves	AP	5H80-394									
	17.35 P.D. 5C Grooves	NA	5H81-1104									
	11.00 P.D. 9C Grooves	AP	5H120-394									
5/6	Flexible Coupling Package (for Direct Drive)											
	MOTOR HP NEMA MOTOR FRAME SIZE MOTOR SHAFT DIA.											
	20 256T 1.625	AP	5H40-613	1								
	25,30 284T,286T 1.875	AP	5H40-623	1	1							
	40,50,60 324TS,326TS,364TS 1.875	AP	5H60-613	1	1	1	1	1		1		
	75 365TS 1.875	AP	5H80-663			1	1	1	1	1		
	100,125 404TS,405TS 2.125	AP	5H120-623				1	1	1		1	
	150,200 444TS,445TS 2.375	AP	5H126-623							1	1	



COMPRESSOR/CONDENSING UNITS

5H
FREON

ITEM NO.	PART NAME	LDC	REPLACEMENT PART NUMBER	UNIT USAGE							
				5H							
				40	46	60	66	80	86	120	126

DRIVE GROUP (CONT'D.)

	Packages 5H40-613 and 5H40-623			1			1												
	Includes:																		
7	Motor Flange																		
	for 1-5/8" Shaft Dia. (1) 5F-21925		NA																
	for 1-7/8" Shaft Dia. (1) 5F-21748		NS																
8	Compressor Flange (1) 5F-21749		NS																
9	Center Ring (1) 5F-11241		AC																
10	Disc (Multiple Rings) (2) 5F-10664		AC																
11	Spacer (6) 5F-11240		AC																
12	Bevel Washer (18) 5F-11205		AC																
13	Short Bolt (6) 5F-10721		AC																
14	Long Bolt (3) 5F-11206		AC																
15	Lock Nut (9) AT61AA-202-012		PT																
	Packages 5H60-613 and 5H60-623			1	1	1	1	1											
	Includes:																		
7	Motor Flange w/short Bushings																		
	for 1-7/8" Shaft Dia. (1) 5F-21753		AC																
	for 2-1/8" Shaft Dia. (1) 5F-21754		AC																
8	Compressor Flange with Short Bushings (1) 5F-21755		AC																
9	Center Ring with Long Bushings (1) 5F-11239		AC																
10	Disc (Multiple Rings) (2) 5F-10624		AC																
12	Bevel Washers (16) 5F-11205		AC																
13	Short Bolt (8) 5F-10721		AC																
14	Long Bolt (4) 5F-11206		AC																
15	Lock Nut (12) AT61AA-202-012		PT																
	Package 5H80-663						1	1	1	1									
	Includes:																		
7	Motor Flange																		
	for 1-7/8" Shaft Dia. (1) 5F-12291		NS																
8	Compressor Flange (1) 5F-21927		NS																
9	Center Ring (1) 5F-10643		AC																
10	Laminated Ring (2) 5F-10689		AC																
NI	Spacing Link (12) 5F-11874		AC																
13	Short Bolt (8) 5F-10634		AC																
14	Long Bolt (4) 5F-11250		AC																
15	Lock Nut (12) AT61AA-242-010		PT																
	Package 5H120-623											1	1	1					
	Includes:																		
7	Motor Flange																		
	2-1/8" Shaft Dia. (1) 5H-22785		AC																
8	Compressor Flange (1) 5H-22781		NA																
16	Center Ring (1) 5H120-20826		NS																
17	Laminated Ring (2) 5H120-10985		AC																
18	Bevel Washer (16) 5H120-11111		AC																
19	Bolt (16) 5H120-10717		AC																
20	Lock Nut (16) AT61AA-242-010		PT																



COMPRESSOR/CONDENSING UNITS

5H
FREON

ITEM NO.	PART NAME	LDC	REPLACEMENT PART NUMBER	UNIT USAGE							
				5H							
				40	46	60	66	80	86	120	126

DRIVE GROUP (CONT'D.)

	Package 5H126-623										1	1
	Includes:											
7	Motor Flange 2-3/8 Shaft Dia.	(1) 5H-15001	NS									
8	Compressor Flange	(1) 5H-24304	NS									
16	Center Ring	(1) 5H126-20752	NS									
17	Laminated Ring	(2) 5H126-10957	NS									
18	Bevel Washer	(16) 5H126-10965	NS									
19	Bolt	(16) 5H126-10966	NS									
20	Lock Nut	(16) AT61AA-242-010	PT									
21	Coupling Guard											
	For use on 24-1/2 wide base		NS	5H40-2293	1	1						
	31-1/2 wide base		NS	5H80-303			1	1	1			
	24-1/2 wide base		NS	5H60-2523			1	1				
	31-1/2 wide base		NS	5H120-2523							1	1
NI	Grommet, Coupling Guard		NS	KA56CR-031	4	4	4	4	4	4	4	4
NI	Compressor Spacer Block		AC	5H40-1422	2	2	2	2	2	2		
			NA	5H120-1422							4	4
NI	Motor Fastening Sets		AP									
22	Belt Guard		NS	5H40-654	1	1	1	1				
			NS	5H60-654			1					
			NS	5H80-654				1	1	1	1	1
23	Compressor Base Assembly		NS	5H40-588	1	1	1	1				
	Direct Drive		NS	5H60-588			1					
	For use with 09RH084 Cond.		NS	5H80-588				1	1	1	1	1
	Belt Drive											
	22-1/2 wide mtg. bolt spacing		NS	5H40-598	1		1	1				
	35-1/2 wide mtg. bolt spacing		NS	5H60-974			1	1	1	1	1	1
NI	Compressor Shim		AC	5H40-1572							As Required	
	3-1/2 x 3-1/8 x .030 thk.laminated brass		AC	5H40-1582							As Required	
NI	Motor Shim		AC	5F40-1702							As Required	
	3-1/2 x 3-3/8 x .030 thk.laminated brass		AC	5F40-1712							As Required	
	3-1/2 x 3-3/8 x .030 thk.C.R.S.		AC	5H60-1702							As Required	
	3-3/4 x 4-3/4 x .030 thk.laminated brass		AC	5H60-1712							As Required	
	3-3/4 x 4-3/4 x .030 thk.C.R.S.		AC								As Required	

CONTROL GROUP

Parts for Oil Safety Switch Package (Early Type) for 5F20-933 Package, 110V, 208/220V, 440V, 550V; AC 50/60 Cycle, and for 5F20-943 Package 230V DC (both used with Single Compressor R-12 or 500).												
ITEM NO.	PART NAME	LDC	REPLACEMENT PART NUMBER	40	46	60	66	80	86	120	126	
NI	Adapter 5/8-18NF x 1/4 FPT	AC	5F20-1311	2	2	2				2	2	
NI	Gasket 5/8	PT	AU51YA-011-012	2	2	2				2	2	
NI	Flare Nut, Short 1/4	AC	DD02CA-051	4	4	4				4	4	
NI	Half Union Coupling 1/4	AC	DD07DA-051	2	2	2				2	2	
24	*Differential Pressure Switch	AC	HK06UC-014	1	1	1				1	1	
25	Time Delay Relay	NA	HN68AD-006	1	1	1				1	1	
26	*Thermal Element	NA	HN71AZ-131	1	1	1				1	1	



COMPRESSOR/CONDENSING UNITS

5H
FREON

ITEM NO.	PART NAME	LDC	REPLACEMENT PART NUMBER	UNIT USAGE							
				5H							
				40	46	60	66	80	86	120	126

CONTROL GROUP (CONT'D.)

27	*Transformer (5F20-933 only)	NA	HT01AC-150	1	1	1	1	1	1	1	1	1
NI	*Resistor (5F20-943 only)	NA	HT21AM-180	1	1	1		1				1
	Oil Safety Switch Package (Latest Type) (R12,22,500) 115V; 230V; AC or DC When used with 440 and 550 volts, a suitable Transformer will be required. Includes:	AP		1	1	1	1	1	1	1	1	1
	SINGLE DUPLEX COMPR. COMPR.											
NI	Adapter (1)		5F20-1311									
NI	Gasket 5/8 (1)		AU51YA-011-012									
NI	Half Union Cplg. 1/4(2)		DD07DA-051									
24	*Differential Pressure Switch w/Time											
	Delay Relay (1)		HK06UL-012									
24	Differential Pressure Switch, No Relay											
			HK06UA-012									
<p>NOTES: * Robertshaw HK06UL-012 Differential Pressure Switch may be used as a replacement for the Pressure Switch, Time Delay Relay and the Transformer (or Resistor on DC) on Early Type Units.</p> <p>** Penn Switch HK06BA-108 supplied on some Compressors using R-12 is replaceable with HK06UL-012.</p>												
NI	Oil Cooler Package	AP	6L45-977	1	1	1	1	1	1	1	1	1
	Includes:											
NI	Oil Cooler (1)		KH52HC-101									
NI	Cooler Bracket (1)		5F41-3342									
NI	Coupling (Oil Cooler) (1)		DD07DA-203									
NI	Cooler Bracket Stud (2)		5H40-1781									
NI	Lockwasher (2)		AU11AR-241									
NI	Hex Nut (2)		AT39AA-241									
NI	Half Union Elbow											
	on 5H40-86 (3)		DD10CA-203									
	on 5H120-126 (1)		DD10CA-203									
	on 5H120-126 (2)		DD10CA-201									
NI	Socket Set Screw 5/8-18 x 5/8 Lg.											
	on 5H40-86 (1)		AF19AR-317									
NI	Headless Plug											
	on 5H120-126 (1)		5H81-2171									
NI	Bearing Head Sleeve											
	on 5H40-86											
	SSN M000264 (1)		5H40-7252									



COMPRESSOR/CONDENSING UNITS

5H
FREON

ITEM NO.	PART NAME	LDC	REPLACEMENT PART NUMBER	UNIT USAGE							
				5H							
				40	46	60	66	80	86	120	126

CONTROL GROUP (CONT'D.)

NI	Electrical Compensated Capacity Control Pkg. Bevel Gear Type - Minn-Honeywell Barber-Coleman Barber-Coleman	NA NA NA	5H40-A203 5H40-A213 5H120-A213	1 1 1	1 1 1	1 1 1	1 1 1	1 1 1	1 1 1	1 1 1	1 1 1	1 1 1	1 1 1
	Includes: ON 5H40 5H40 5H120 A203 A213 A213												
NI	Control Motor (1)	AC	HF25AA-001										
	(1) (1) (1)	NS	HF12CB-116										
NI	Transformer (1)	NS	HT01AA-115										
NI	Relay (1)	NS	HN61DJ-005										
NI	Bevel Gear Assy (1)	AC	5F40-A772										
	(1) (1) (1)	NA	5F40-A762										
NI	Bevel Gear Assy (1)	AC	5F40-791										
NI	Special Stud (4)	AC	5H40-6712										
NI	Support Plate (1)	SM3	5H40-2723										
	(1) (1) (1)	NS	5H120-2723										
NI	Outer Valve Assy (1)	NA	5F40-A782										
NI	Hex Hd. Screw 1/4-20 x 1" Lg (4)	AC	AA06BS-170										
NI	Mach. Screw Nut 1/4-20 (4)	AC	AT39AB-171										
NI	Plain Washer (4)	PT	AU01AB-171012										
NI	Lockwasher (6)	PT	AU11AS-171012										
NI	Flanged Bearing (1)	NA	KT66CX-031										
NI	Hex Hd. Screw 1/4-20 x 3/8" Lg. (2)	NS	AA06BS-164										
NI	F.H. Socket Screw (4)	NS	AC27FR-166										
NI	Grease Fitting (1)	NA	CW12CB-502										
	(1) (1) (1)	NA	CW14FA-066										
NI	Capscrew Gasket (4)	PT	AU51YA-009012										

Parts for Electrical Compensated Capacity Control - Spur Gear Type - (Motor, Transformer and Relay) are same as on Bevel Gear Type).

NI	Spur Gear - 3" P.D. on Minn-Honeywell	NA	5F40-771	1	1	1	1	1	1	1	1	1	1
	2-1/2" P.D. on Barber-Coleman	NA	5F40-761	1	1	1	1	1	1	1	1	1	1
NI	Spur Gear - 5/8" P.D.	AC	5F40-751	1	1	1	1	1	1	1	1	1	1
NI	Support Bracket	NA	5F40-4702	1	1	1	1	1	1	1	1	1	1
NI	Motor Bracket	NA	5F40-2183	1	1	1	1	1	1	1	1	1	1
NI	Control Valve Assembly	AC	5F40-A332	1	1	1	1	1	1	1	1	1	1
NI	Cone Pt. Set Screw	NS	5F40-3791	1	1	1	1	1	1	1	1	1	1



COMPRESSOR/CONDENSING UNITS

5H
FREON

ITEM NO.	PART NAME	LDC	REPLACEMENT PART NUMBER	UNIT USAGE							
				5H							
				40	46	60	66	80	86	120	126
CONDENSER GROUP											
28	5H40-369: 25 Ton, 10-3/4 Dia. Shell, 2-1/2 O.D. Hot Gas Inlet, 4 and 8 Pass. Includes:	NA		1		1					
29	Front Water Head (1) 5H40-1204	AC									
30	Rear Water Head (1) 5H40-1214	AC									
31	Front Water Head Gasket (2) 09RA022-1282	AC									
	Trim Out Webbing and Use										
NI	Pass Partition Gasket(5') <i>∅See Note</i>	AC									
NI	Try Cock Assy. (1) 7F0-132	AC									
32	Relief Valve (1) EB51LZ-183	AC									
33	Angle Valve (Regulating) (1) EP23LC-090	AC									
34	Liquid Shut-Off Valve (1) EN07EA-039	AC									
35	Shut Off Valve Gasket (1) 55452	AC									
NI	Tru-Fin Tube										
	3/4 OD x 70-1/4 Lg. (64) 5H40-3082	AC									
	Stud Bolt (16) ARO7AA-513	AC									
28	5H40-419: 25 Ton, 10-3/4 Dia. Shell, 2-1/8 O.D. Hot Gas Inlet, 4 and 8 Pass. Same as 5H40-369 except:	NA		1		1					
	<u>ADD:</u>										
NI	Angle Valve (Purge) (1) EP23SC-090	AC									
28	5H40-369-2: 25 Ton Similar to 5H40-369 except for the following parts:	NA									
29	Front Water Head (1) 5H40-B-3578-1	NS									
30	Rear Water Head (1) 5H40-B-3579-1	NS									
31	Water Head Gasket (2) 5H40-B-3584	AC									
NI	Tru-Fin Tube	AC									
	3/4 O.D. x 70-1/4 Lg. (60) 5H40-3082	AC									
28	5H60-419: 37-1/2 Ton, 12-3/4" Dia. Shell 2-5/8 O.D. Hot Gas Inlet, 4 and 8 Pass.	NA									
	5H80-419: 50 Ton, 12-3/4 Dia. Shell 3-1/8 O.D. Hot Gas Inlet, 4 and 8 Pass.	NA									
	Each Includes: ON										
	5H60 5H80										
29	Front Water Head (1) (1) 5H60-1203	AC									
30	Rear Water Head (1) (1) 5H60-1213	AC									
31	Water Head Gasket (2) (2) 09RA043-1332	AC									
	Trim Out Webbing and Use										
NI	Pass Partition Gasket (6') <i>∅See Note</i>	AC									
NI	Try Cock Assy. (1) (1) 7F0-132	AC									
NI	Angle Valve (Purge) (1) (2) EP23SC-090	AC									
32	Relief Valve (1) (1) EB51LZ-183	AC									
33	Angle Valve (Reg.) (1) (1) EP23LC-090	AC									
34	Liquid Valve (1) (1) EN07EA-039	AC									
	(1) EN07EA-041	AC									
35	Shut Off Valve Gskt (1) (1) 55452	AC									
NI	Tru-Fin Tube 3/4 O.D.										
	x 70-1/4 Lg. (96) 5H40-3082	AC									
	Tru-Fin Tube 3/4 O.D.										
	x 86-1/4 Lg. (104) 5H80-3082	AC									
36	Stud Bolt (16) (16) ARO8AA-700	AC									



COMPRESSOR/CONDENSING UNITS

5H FREON

ITEM NO.	PART NAME	LDC	REPLACEMENT PART NUMBER	UNIT USAGE							
				5H							
				40	46	60	66	80	86	120	126
CONDENSER GROUP (CONT'D.)											
28	5H60-369: 37-1/2 Ton, 12-3/4 Dia. Shell, 3 Dia. Hot Gas Inlet, 4 and 8 Pass.	NA			1		1		1		
	5H80-369: 50 Ton, 12-3/4 Dia. Shell, 3 Dia. Hot Gas Inlet, 4 and 8 Pass.	NA			1		1		1		
	Each Includes: ON										
	5H60 5H80										
29	Front Water Head (1) (1) 5H60-1203	AC									
30	Rear Water Head (1) (1) 5H60-1213	AC									
31	Water Head Gasket (2) (2) 09RA043-1332	AC									
	Trim Out Webbing and Use										
NI	Pass Partition Gasket (6') <i>∅See Note</i>	AC									
NI	Try Cock Assy. (1) (1) 7F0-132	AC									
32	Relief Valve (1) (1) EB51LZ-183	AC									
33	Angle Valve (Reg.) (1) (1) EP23LC-090	AC									
34	Liquid Valve (1) EN07EA-039	AC									
	(1) EN07EA-041	AC									
35	Liquid Valve Gskt (1) (1) 55452	AC									
NI	Tru-Fin Tube 3/4 O.D.										
	x 70-1/4 Lg. (96) 5H40-3082	AC									
	Tru-Fin Tube 3/4 O.D.										
	x 86-1/4 Lg. (104) 5H80-3082	AC									
36	Stud Bolt (16) (16) AR08AA-700	AC									
28	5H60-369-1: 37 Ton	NA			1		1		1		
	Similar to 5H60-369										
	5H80-369-3: 50 Ton	NA			1		1		1		
	Similar to 5H80-369										
	Except for the following parts:										
29	Front Water Head (1) 5H60-B-3569-1	AC									
31	Front Water Head Gasket (1) 5H60-B-3573	AC									
30	Rear Water Head (1) 5H60-B-3570-1	NS									
31	Rear Water Head Gasket (1) 5H60-3573	AC									
NI	Tubes for 5H60 (92) 5H40-C-3082	NA									
	5H80 (92) 5H80-D-3921-8	NA									
28	5H100-419: 75 Ton, 14" Dia. Shell, 3-1/8 O.D. Hot Gas Inlet, 3 and 6 Pass.	NS						1		1	
	5H120-419: 100 Ton, 14" Dia. Shell, 3-3/8 O.D. Hot Gas Inlet, 3 and 6 Pass.	NS						1		1	
	Each Includes: ON										
	5H100 5H120										
29	Front Water Head (1) (1) 5H80-1204	AC									
30	Rear Water Head (1) (1) 5H80-1214	AC									
31	Water Head Gskt (2) (2) 09RA084-1203	AC									
	Trim Out Webbing and Form New Webbing										
NI	Pass Partition Gasket (6') <i>∅See Note</i>	AC									
NI	Try Cock Assy. (1) (1) 7F0-132	AC									
NI	Angle Valve (Purge) (2) (2) EP23SC-090	AC									
NI	Relief Valve PSN 4350200										
	300 PSI (1) (1) EB51FK-700	AC									
34	Liquid Shut-Off Valve (1) (1) EM13FA-516	AC									
35	Shut-Off Valve Gskt (1) (1) 5H80-3591	AC									
NI	Butt Weld Adapter										
	(Water Connection) (2) (2) EP29CW-570	NS									
NI	Companion Flange (2) (2) EP29ZC-600	NA									
NI	Water Conn. Gasket (2) (2) 5H80-4962	AC									



COMPRESSOR/CONDENSING UNITS

5H FREON

ITEM NO.	PART NAME	LDC	REPLACEMENT PART NUMBER	UNIT USAGE							
				5H							
				40	46	60	66	80	86	120	126

CONDENSER GROUP (CONT'D.)

28	5H100-419: 75 Ton, 14" Dia. Shell, 3-1/8 O.D. Hot Gas Inlet, 3 and 6 Pass.	NS							1		1
	5H120-419: 100 Ton, 14" Dia. Shell, 3-3/8 O.D. Hot Gas Inlet, 3 and 6 Pass. (Cont'd.)	NS									
	Each Includes: ON										
	5H100 5H120										
NI	Tru Fin Tubes 3/4 O.D. x 86-1/4 Lg. (126) 5H80-3082	AC									
	Tru Fin Tubes 3/4 O.D. x 109-7/8 Lg. (126) 9T6-3092	AC									
NI	Stud Bolt (16) (16) ARO8AA-700	AC									
28	5H140-419: 125 Ton, 18" Dia. Shell 3-5/8 O.D. Hot Gas Inlet, with Integral Support Feet	NA							1		1
	Includes:										
29	Front Water Head (1) 09RA127-1094	AC									
30	Rear Water Head (1) 09RA127-1114	AC									
31	Water Head Gasket (2) 09RA127-1223	AC									
NI	Pass Partition Gasket (7') <i>ØSee Note</i>	AC									
NI	Try Cock Assembly (1) 7F0-132	AC									
NI	Angle Valve (Purge) (1) EP23SC-090	AC									
32	Relief Valve										
	PSN 4350200-300 PSI (1) EB51FK-780	NA									
	SSN 4350200-385 PSI (1) EB51FK-702	NA									
33	Angle Valve (1) EP23LC-090	AC									
34	Liquid Shut-Off Valve (1) EMI3FA-516	AC									
NI	Butt Weld Adapter										
	(Water Connection) (2) EP29WC-660	NA									
NI	Water Conn. Gasket (2) 6L125-1402	AC									
NI	Tru-Fin Tubes 3/4 O.D. x 86-1/4 Lg. (222) 5H80-3082	AC									
35	Shut-Off Valve Gasket (1) 5H80-3591	AC									
36	Stud Bolt (24) ARO8AA-700	AC									

Early Type Condenser w/Flanged Gas Inlet Connection are the same as 5H Condensers except for the following parts:

NI	Early Type 5H40-419										
	Included:										
37	Discharge Line Adapt. (1) 5H40-1402	NA									
38	Adapter Flange (1) 5H40-1173	NA									
39	Adapter Gasket (1) 7G8-0422	AC									
NI	Early Type 5H60-419										
	Included										
37	Discharge Line Adapt. (1) 5H60-1412	NA									
38	Adapter Flange (1) 5H60-1173	NA									
39	Adapter Gasket (1) CR90QA-501	AC									
NI	Early Type 5H80-419 and 5H100-419										
	Included:										
37	Discharge Line Adapt. (1) 9T8-1162	NA									
38	Adapter Flange (1) 9T8-1172	NA									
39	Adapter Gasket (1) CR90QA-501	AC									

Ø NOTE: Gasketing available in bulk only. Order (1) LF50SP-001 (5 lb. roll approx. 55 ft. lg. 3/32 thk x 7/32 wide). Cut to suit.



COMPRESSOR/CONDENSING UNITS

5H

FREON

ITEM NO.	PART NAME	LDC	REPLACEMENT PART NUMBER	UNIT USAGE							
				5H							
				40	46	60	66	80	86	120	126

CONDENSER GROUP (CONT'D.)

Early Type Condenser w/Flanged Gas Inlet Connection are the same as 5H Condensers except for the following parts: (Continued)											
NI	Early Type 5H120-419										
	Included:										
37	Discharge Line Adapter (1) EP29VC-721	AC									
38	Adapter Flange (1) EP29ZC-690	NA									
39	Adapter Gasket (1) EP29YC-720	AC									

REPLACEMENT SHELL AND TUBE CONDENSERS

28	Replacement for 5H40 Condenser, 27 Ton, 3 and 6 Pass. w/Sub Cooler (If Complete Replacement Condenser is required, order 09RH027101 from Finished Goods) Each Includes:	NS	09RH027109	1							
29	Inlet Water Head (1) 09RA022-1094	AC									
30	Outlet Water Head (1) 09RA022-1114	AC									
31	Inlet Water Head Gasket (1) 09RA022-1302	AC									
31	Outlet Water Head Gasket (1) 09RA022-1292	AC									
NI	Try Cock Assembly (1) 7F0-132	AC									
NI	Angle Valve (Purge) (1) EP23SC-090	AC									
32	Pressure Relief Valve (1) EB51LZ-183	AC									
33	Angle Valve (Reg.) (1) EP23LC-090	AC									
34	Liquid Shut-Off Valve (1) EN07EA-039	AC									
35	Shut-Off Valve Gasket (1) 6D68-1131-012	PT									
NI	Tru Fin Tubes (3/4 O.D. x 70-1/4 Lg.) PSN 9916028 (56) 5H40-3082 SSN 9916028 (39) 99TF501804 (Tube quantities do not include special sub cooler tubes)	AC AC									
36	Stud Bolt (4) (16) AR07AA-513	AC									
36	Hex Head Bolt (12) AA06BR-330	AC									
28	Replacement for 5H60 Condenser, 43 Ton, 3 and 6 Pass. w/Sub Cooler (If Complete Replacement Condenser is required, order 09RH043284 from Finished Goods)	NS	09RH043284	1	1	1	1	1			
	Replacement for 5H80 Condenser, 54 Ton, 3 and 6 Pass. w/Sub Cooler (If Complete Replacement Condenser is required, order 09RH054294 from Finished Goods)	NS	09RH054294		1	1		1			1
	Condenser Assy. (Externally identical with 09RH054), 70 Ton, 3 and 6 Pass. w/Sub Cooler (If Complete Replacement Condenser is required, order 09RH070284 from Finished Goods) All 12-3/4 Dia. Shells Each Includes:	NS	09RH070284	1	1	1	1	1	1	1	
29	Inlet Water Head (1) 09RA043-1023	AC									
30	Outlet Water Head (1) 09RA043-1043	AC									
31	Inlet Water Head Gasket (1) 09RA043-1322	AC									
31	Outlet Water Head Gasket (1) 09RA043-1312	AC									
NI	Try Cock Assembly (1) 7F0-132	AC									
NI	Angle Valve-09RH043 Only (1) EP23SC-090	AC									



COMPRESSOR/CONDENSING UNITS

5H
FREON

ITEM NO.	PART NAME	LDC	REPLACEMENT PART NUMBER	UNIT USAGE							
				5H							
				40	46	60	66	80	86	120	126

REPLACEMENT SHELL AND TUBE CONDENSERS (CONT'D.)

28	Continued																			
	Each Includes:																			
32	Pressure Relief Valve (1) EB51LZ-183	AC																		
33	Angle Valve																			
	on 09RH043 (1) EP23LC-090	AC																		
	on 09RH054 and 070 (2) EP23LC-090	AC																		
34	Liquid Shut-Off Valve																			
	on 09RH043 (1) EN07EA-039	AC																		
	on 09RH054 and 070 (1) EN07EA-041	AC																		
35	Liquid Shut-Off Valve																			
	Gasket (1) 6D68-1131-012	PT																		
NI	Tru Fin Tube 09RH043 3/4 OD x 70-1/4 Lg.																			
	PSN 9916028 (84) 5H40-3082	AC																		
	SSN 9916028 (61) 99TF501804	AC																		
	09RH054 3/4 OD x 86-1/4 Lg.																			
	PSN 9916028 (84) 5H80-3082	AC																		
	SSN 9916028 (61) 99TF501814	AC																		
	09RH070 3/4 OD x 86-1/4 Lg.																			
	PSN 9916028 (105) 5H80-3082	AC																		
	SSN 9916028 (75) 99TF501814	AC																		
	<i>(Tube quantities do not include special sub-cooler tubes)</i>																			
36	Stud Bolt (4) (16) AR08AA-700	AC																		
36	Hex Head Bolt (12) AA06BR-365	NS																		
28	Replacement for 5H100 Condenser, 24 Ton, 3 and 6 Pass., w/Sub Cooler (If Complete Replacement Condenser is required, order 09RH084101 from Finished Goods)	NS	09RH084109							1	1	1	1	1						
	Replacement for 5H120 Condenser, 97 Ton, 3 and 6 Pass., w/Sub Cooler (If Complete Condenser is required, order 09RH097101 from Finished Goods)																			
	Includes:																			
29	Inlet Water Head (1) 09RA084-1094	AC																		
30	Outlet Water Head (1) 09RA084-1114	AC																		
31	Inlet Water Head Gasket (1) 09RA084-1203	AC																		
31	Outlet Water Head Gasket (1) 09RA084-1193	AC																		
NI	Try Cock Assembly (1) 7F0-132	AC																		
NI	Angle Valve (Purge) (1) EP23SC-090	AC																		
32	Pressure Relief Valve (1) EB51FZ-241	AC																		
33	Angle Valve (Reg.) (1) EP23LC-090	AC																		
34	Liquid Shut-Off Valve (1) EM13FA-516	AC																		
35	Liquid Valve Gasket (1) 5H80-3591	AC																		
NI	Tru Fin Tube 09RH084 3/4 OD x 86-1/4 Lg.																			
	PSN 9916028 (121) 5H80-3082	AC																		
	SSN 9916028 (85) 99TF501814	AC																		
	09RH097 3/4 OD x 109-7/8 Lg.																			
	PSN 9916028 (124) 9T6-3092	AC																		
	SSN 9916028 (85) 99TF501824	AC																		
	<i>(Tube quantities do not include special sub-cooler tubes)</i>																			
36	Stud Bolt (4) (16) AR08AA-700	AC																		
36	Hex Head Bolt (12) AA06BR-365	NA																		
NI	Water Inlet Assy. (2) 09RA084-102	NA																		
NI	Water Inlet Gasket (2) 5H80-4962	AC																		



COMPRESSOR/CONDENSING UNITS

5H
FREON

ITEM NO.	PART NAME	LDC	REPLACEMENT PART NUMBER	UNIT USAGE							
				5H							
				40	46	60	66	80	86	120	126
REPLACEMENT SHELL AND TUBE CONDENSERS (CONT'D.)											
28	Replacement for 5H140 Condenser, 127 Ton, 3 and 6 Pass., w/Sub Cooler (with Integral Mounting Feet) (If Complete Replacement Condenser is required, order 09RH127101 from Finished Goods) Includes:	NA	09RH127109							1	1
29	Inlet Water Head (1) 09RA127-1094	AC									
30	Outlet Water Head (1) 09RA127-1114	NS									
31	Inlet Water Head Gasket (1) 09RA127-1223	AC									
31	Outlet Water Head Gasket (1) 09RA127-1213	AC									
NI	Try Cock Assembly (1) 7FO-132	AC									
NI	Angle Valve (Purge) (1) EP23SC-090	AC									
32	Pressure Relief Valve (1) EB51FZ-241	AC									
34	Liquid Shut-Off Valve (1) EML3FA-516	AC									
35	Liquid Valve Gasket (1) 5H80-3591	AC									
NI	Tru Fin Tube 3/4 OD x 86-1/4 Lg. PSN 9916028 (198) 5H80-3082 SSN 9916028 (142) 99TF501814 (Tube quantity do not include special sub-cooler tubes)	AC AC									
36	Stud Bolt (4) (24) ARO8AA-700	AC									
36	Hex Head Bolt (20) AA06BR-365	NA									
NI	Water Inlet Assy. (2) 09RA127-102	NS									
NI	Water Inlet Gasket (2) 6L125-1402	AC									
40	Condenser Support (Used with 5F Condenser) (Used with 10-3/4 Dia. Condenser) 22-1/2 Mtg. Bolt Spacing (Used with 12-3/4 Dia. Condenser) 35-1/2 Mtg. Bolt Spacing (Used with Belt Drive) 29-1/2 Mtg. Bolt Spacing (Used with Direct Drive)	NA NSS NSS NSS NSS	5H40-1193 5H40-1373 5H60-1373 5H80-1284 5H80-1274	2 2 2 2 2	2 2 2 2 2	2 2 2 2 2	2 2 2 2 2	2 2 2 2 2	2 2 2 2 2	2 2 2 2 2	2 2 2 2 2
41	Condenser Strap (Used with 10-3/4 Dia. Condenser) (Used with 10-3/4 Dia. Condenser) 22-1/2 Mtg. Bolt Spacing 12-3/4 Dia. Cond. 12-3/4 Dia. Cond. 14 Dia. Cond.	NSS NSS AC NSS AC	5H40-1662 5H40-1672 5H60-1662 5H80-3072 5H120-3072	2 2 4 4 4	2 2 4 4 4	2 2 4 4 4	2 2 4 4 4	2 2 4 4 4	2 2 4 4 4	2 2 4 4 4	2 2 4 4 4
42	Condenser Strap Liner (May have to cut to required length)	AC	5H120-1682	4	4	4	4	4	4	4	4
NI	Tube Brush (Nylon)	AC	KC21AH-105	As Required							



COMPRESSOR/CONDENSING UNITS

5H

FREON

ITEM NO.	PART NAME	LDC	REPLACEMENT PART NUMBER	UNIT USAGE							
				5H							
				40	46	60	66	80	86	120	126
COMPRESSOR SHUT-OFF VALVE GROUP											
43	Discharge Shut-Off Valve 2-1/8" ODS (4 Bolt Mtg., 3-1/16 Bolt Ctrs) 2-1/8" ODS (4 Bolt Mtg., 3-1/4 Bolt Ctrs) Includes:	AC AC	EM13FA-516 EM13FC-521	1 1	1 1						
44	Adapter (Tailpiece) (1) EP29VC-540	AC									
45	Companion Flange (1) EP29ZC-560	NA									
46	Adapter Gasket (1) EP29YC-560	AC									
NI	Seal Cap (1) EN99ZA-018	AC									
NI	Seal Cap Gasket (1) EN99ZA-109	AC									
43	Discharge Shut-Off Valve 3-1/8" ODS (4 Bolt Mtg., 3-7/8 Bolt Ctrs) 2-5/8" ODS (8 Bolt Mtg., 4-3/4 Bolt Circle) 8 Bolt Mounting Valve Includes:	AC NA	EM13FA-520 EM13GC-552			1 1	1 1				
44	Adapter (Tailpiece) (1) EP29VC-600	AC									
45	Companion Flange (1) EP29ZC-660	AC									
46	Adapter Gasket (1) EP29YC-660	AC									
NI	Seal Cap (1) EN99ZA-021	AC									
NI	Seal Cap Gasket (1) EN99ZA-110	AC									
43	Discharge Shut-Off Valve 3-1/8" ODS (4 Bolt Mtg., 3-7/8 Bolt Ctrs) 3-1/8" ODS (8 Bolt Mtg., 4-3/4 Bolt Circle) 8 Bolt Mounting Valve Includes:	AC NA	EM13FA-520 EM13GC-553					1 1	1 1		
44	Adapter (Tailpiece) (1) EP29VC-660	AC									
45	Companion Flange (1) EP29ZC-660	AC									
46	Adapter Gasket (1) EP29YC-660	AC									
NI	Seal Cap (1) EN99ZA-021	AC									
NI	Seal Cap Gasket (1) EN99ZA-110	AC									
43	Discharge Shut-Off Valve 4-1/8" ODS (4 Bolt Mtg., 4-13/16 Bolt Ctrs) 3-5/8" ODS (8 Bolt Mtg., 5-1/2 Bolt Circle) 8 Bolt Mounting Valve Includes:	AC NA	EM13FA-524 EM13GC-555							1 1	
44	Adapter (Tailpiece) (1) EP29VC-721	AC									
45	Companion Flange (1) EP29ZC-680	AC									
46	Adapter Gasket (1) EP29YC-720	AC									
NI	Seal Cap (1) EN99ZA-021	AC									
NI	Seal Cap Gasket (1) EN99ZA-110	AC									
47	Suction Shut-Off Valve 3-1/8" ODS (4 Bolt Mtg., 3-7/8 Bolt Ctrs) 3-1/8" ODS (8 Bolt Mtg., 4-3/4 Bolt Circle) 8 Bolt Mounting Valve Includes:	AC NA	EM13FA-520 EM13GC-553			1 1	1 1				
44	Adapter (Tailpiece) (1) EP29VC-660	AC									
45	Companion Flange (1) EP29ZC-660	AC									
46	Adapter Gasket (1) EP29YC-660	AC									
NI	Seal Cap (1) EN99ZA-021	AC									
NI	Seal Cap Gasket (1) EN99ZA-110	AC									
47	Suction Shut-Off Valve 2-5/8" ODS (4 Bolt Mtg., 3-1/16 Bolt Ctrs) 2-5/8" ODS (4 Bolt Mtg., 3-1/4 Bolt Ctrs) Includes:	AC AC	EM13FA-518 EM13FC-551	1 1	1 1						
44	Adapter (Tailpiece) (1) EP29VC-601	AC									
45	Companion Flange (1) EP29ZC-570	AC									
46	Adapter Gasket (1) EP29YC-570	AC									
NI	Seal Cap (1) EN99ZA-018	AC									
NI	Seal Cap Gasket (1) EN99ZA-109	AC									



COMPRESSOR/CONDENSING UNITS

5H
FREON

ITEM NO.	PART NAME	LDC	REPLACEMENT PART NUMBER	UNIT USAGE							
				5H							
				40	46	60	66	80	86	120	126

COMPRESSOR SHUT-OFF VALVE GROUP (CONT'D.)

47	Suction Shut-Off Valve	AC	EM13FA-520	1					1	1		
	3-1/8" ODS (4 Bolt Mtg., 3-7/8 Bolt Ctrs)	NA	EM13GC-555						1	1		
	3-5/8" ODS (8 Bolt Mtg., 5-1/2 Bolt Circle)											
	For breakdown of 8 Bolt Valve, see previous page											
48	Suction Shut-Off Valve	AC	EM13FA-524								1	1
	4-1/8" ODS (4 Bolt Mtg., 4-13/16 Bolt Ctrs)	NA	EP24ZC-780								1	1
	4-1/8" ODS (8 Bolt Mtg., 7-5/8 Bolt Circle)											
	8 Bolt Mounting Valve Includes:											
NI	Seal Cap Gasket (1) EN99ZA-110	AC										
49	4-1/8" Solder Adapter	NA	EP29VC-780								1	1
50	Adapter Companion Flange	NA	EP29ZC-780								1	1
51	Companion Flange Gasket 5.125 OD x 4.437 ID	AC	EP29YC-780								1	1
52	Valve Gasket, Suction and Discharge (Ring)	PT	5H40-1361-012	2	2							
	Suction and Discharge 8 Bolt	PT	5H60-1632-012			2	2					
	Discharge (8 Bolt Valve)	PT	5H60-1632-012					1	1			
	Suction (8 Bolt Valve)	PT	5H80-1632-012					1	1			
	Discharge (8 Bolt Valve)	PT	5H80-1632-012							1	1	
	Suction (8 Bolt Valve)	AC	ER99TF-560							1	1	
	Suction and Discharge (4 Bolt)	AC	6L65-1101					2	2			
Suction and Discharge (4 Bolt)	AC	EP29YC-780								2	2	
53	Hex Head Capscrew											
	5/8"-11 x 2-1/2" (Suction and Discharge)	AC	AH06BR-327	8	8							
	3/8"-16 x 1-1/2" (Suction and Discharge)	PT	AA06BR-233-012			16	16	8	8			
	1/2"-13 x 1-1/2" (Suction)	AC	AA06BR-293					8	8			
	1/2"-10 x 2-1/2" (Discharge) (8 Bolt Valve)	PT	AA06BR-297-010							8	8	
	3/4"-10 x 2-3/4" (Suction) (8 Bolt Valve)	AC	AA06BR-358							8	8	
	3/4"-10 x 6-1/2" (Suction and Discharge) (4 Bolt Valve)	NS	AH06BR-741								8	8
	Hex Nut 1/2"-13 (8 Bolt Valve)	PT	AT11AA-301-012								8	8

NOTE: Shut Off Valves on compressors built before 1953 do not use the component parts shown here. Order complete replacement valves.



COMPRESSOR/CONDENSING UNITS

5H
FREON

ITEM NO.	PART NAME	LDC	REPLACEMENT PART NUMBER	UNIT USAGE							
				5H							
				40	46	60	66	80	86	120	126

NOTE: In June, 1973 there was a very complex change of service valves and manifolds.

The following is a breakdown of what valves were used prior to this change and what replacement valves and components replace these no longer available 8 bolt valves. You will note on 5H120-126 compressor that replacement manifolds are also required, because of unavailable 8 bolt manifolds.

(ORIGINAL 4 & 8 BOLT VALVES) COMPRESSOR PRIOR JUNE, 1973		LDC	(4 BOLT VALVES) STARTING JUNE, 1973		LDC
5H40-46	Suction Valve EM13FC-551 4 Bolt 2-5/8 ODS 3-1/4 Bolt Centers	AC	Suction Valve EM13FA-518 2-5/8 ODS 3-1/16 Bolt Centers Adapter 5H40-3273 Gasket 5H40-1361-012 Gasket 6G65-1061-012	AC AC PT PT	
	Discharge Valve EM13FC-521 4 Bolt 2-1/8 ODS 3-1/4 Bolt Centers	AC	Discharge Valve EM13FA-516 2-1/8 ODS 3-1/16 Bolt Centers Adapter 5H40-3273 Gasket 5H40-1361-012 Gasket 6G65-1061-012	AC AC PT PT	
5H60-66	Suction Valve EM13GC-553 8 Bolt 3-1/8 ODS 4-3/4 Dia. Bolt Circle	NA	Suction Valve EM13FA-520 3-1/8 ODS 3-7/8 Bolt Centers Adapter 5H80-1774 Gasket 5H60-1632-012 Gasket 6L65-1101	AC AC PT AC	
	Discharge Valve EM13GC-552 8 Bolt 2-5/8 ODS 4-3/4 Dia. Bolt Circle	NA	+Discharge Valve EM13FA-520 3-1/8 ODS 3-7/8 Bolt Centers Adapter 5H80-1774 Gasket 5H60-1632-012 Gasket 6L65-1101	AC AC PT AC	
5H80-86	Suction Valve EM13GC-555 8 Bolt 3-5/8 ODS 5-1/2 Dia. Bolt Circle	NA	+Suction Valve EM13FA-520 3-1/8 ODS 3-7/8 Bolt Centers Adapter 5H80-1794 Gasket 5H80-1632-012 Gasket 6L65-1101	AC AC PT AC	
	Discharge Valve EM13GC-553 8 Bolt 3-1/8 ODS 4-3/4 Dia. Bolt Circle	NA	Discharge Valve EM13FA-520 3-1/8 ODS 3-7/8 Bolt Centers Adapter 5H80-1774 Gasket 5H80-1632-012 Gasket 6L65-1101	AC AC PT AC	
5H120-126	Suction Valve EP24ZC-780 8 Bolt 4-1/8 ODS 7-5/8 Dia. Bolt Circle	NA	Suction Valve EM13FA-524 4-1/8 ODS 4-13/16 Bolt Centers Gasket EP29YC-780 <i>(No Adapter available. If 8 Bolt Suction Valve must be replaced, you must change Suction Manifold to 4 Bolt Valve Type 5H120-1299).</i>	AC AC	
	Discharge Valve EM13GC-555 8 Bolt 3-5/8 ODS 5-1/2 Dia. Bolt Circle	NA	+Discharge Valve EM13FA-524 4-1/8 ODS 4-13/16 Bolt Centers Gasket EP29YC-780 <i>(No Adapter available. If 8 Bolt Disch. Valve must be replaced, you must change Discharge Manifold to 4 Bolt Valve Type 5H120-1279)</i>	AC AC	

+Connection sizes differ from original 8 Bolt Valves and require Reducing Couplings to be added to Suction or Discharge Line.



COMPRESSOR/CONDENSING UNITS

5H
FREON

ITEM NO.	PART NAME	LDC	REPLACEMENT PART NUMBER	UNIT USAGE							
				40	46	60	66	80	86	120	126

MISCELLANEOUS GROUP

54	Muffler Package 2-5/8" ODF 3-1/8" ODF or 3-5/8" ODM	AP AP		1	1	1	1	1	1	1	1
NI	Vibration Isolation Packages	AP									
55	Water Regulating Valve	CD									
NI	Compressor Oil Suitable for use with Carrene 12, 22 and 500. Used with Hermetic Compressors with Evaporator Temperature above -70°. Used with Reciprocating Compressors with Evaporator Temperature above -120°. Viscosity @ 100°F SSU - 150 ± 10 @ 200°F SSU - 40 - 45	CD	PP33-2	As Required							

COMPRESSOR/CONDENSING UNITS

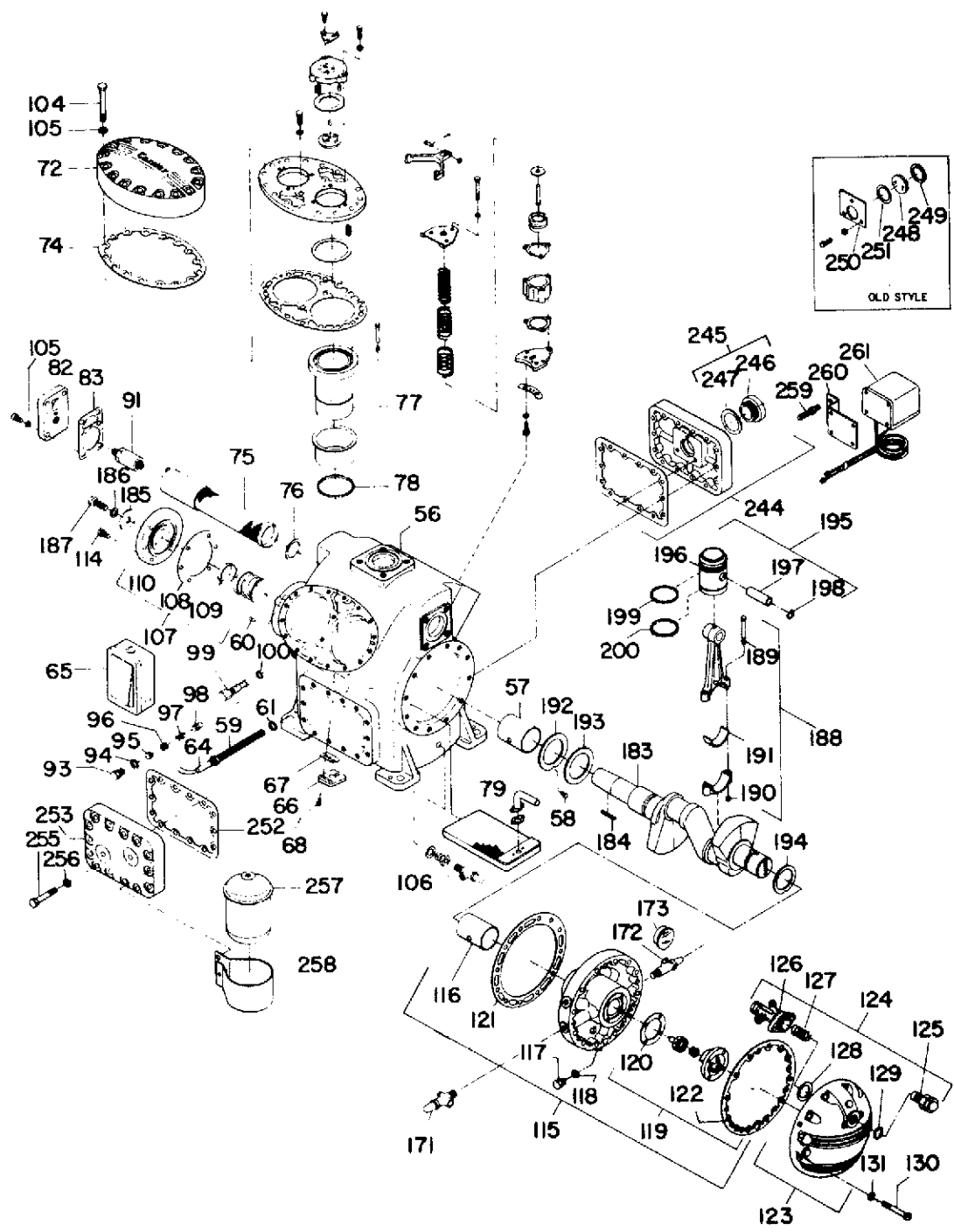

COMPRESSOR
(5H40 shown)



COMPRESSOR/CONDENSING UNITS

5H

FREON

LEGEND 5H40

ITEM NO.	PART NAME	ITEM NO.	PART NAME
56.	Crankcase Assembly	124.	Control Valve Package
57.	Main Bearing	125.	External Valve Assembly
58.	Grove Pin	126.	Valve Body w/Bellows
59.	Heater Casing	127.	Spring
60.	Dowel Pin	128.	Valve Gasket Inner
61.	Magnetic Plug	129.	Valve Gasket Outer
64.	Crankcase Heater Element	130.	Socket Head Capscrew
65.	Crankcase Heater Relay	131.	Capscrew Gasket
66.	Oil Return Check Valve	171.	Double Branch Angle Valve
67.	Check Valve Gasket	172.	Angle Valve
68.	Check Valve Screw, Self Tapping	173.	Oil Pressure Gauge
72.	Cylinder Head	183.	Crankshaft
74.	Cylinder Head Gasket	184.	Flywheel Drive Key
75.	Suction Strainer Assembly	185.	Flywheel Washer
76.	Suction Strainer Gasket	186.	Flywheel Lockwasher
77.	Cylinder Sleeve	187.	Flywheel Capscrew
78.	Cylinder Sleeve Snap Ring	188.	Connecting Rod Package
79.	Oil Screen Package	189.	Connecting Rod Bolt
82.	Manifold Cover	190.	Connecting Rod Nut
83.	Manifold Cover Gasket	191.	Connecting Rod Bearing Half
91.	Internal Relief Valve	192.	Seal End Bearing Washer
93.	Oil By-Pass Plug	193.	Seal End Trust Washer
94.	Oil By-Pass Plug Gasket	194.	Pump End Bearing Washer
95.	Oil By-Pass Lockscrew	195.	Piston and Pin Assembly
96.	Oil By-Pass Adjusting Screw	196.	Piston
97.	Oil By-Pass Spring	197.	Piston Pin
98.	Oil By-Pass Valve	198.	Piston Pin Lock Ring
99.	Non-Adjustable Oil Pressure Reg. Pkg.	199.	Piston Ring - Oil
100.	Gasket	200.	Piston Ring - Compression
104.	Cylinder Head Capscrew	244.	Hand Hole Cover and Sight Glass Assembly
105.	Cylinder Head Capscrew Gasket	245.	Sight Glass Package
106.	Angle Valve	246.	Sight Glass
107.	Replacement Seal Package	247.	Sight Glass Gasket
108.	Cover Plate Gasket	248.	Sight Glass
109.	Carbon Washer	249.	Inner Gasket
110.	Cover Plate	250.	Sight Glass Clamping Guard
114.	Capscrew	251.	Outer Gasket
115.	Bearing Head and Oil Pump Assembly	252.	Hand Hole Cover Gasket
116.	Main Bearing	253.	Hand Hole Cover Plain
117.	Magnetic Plug	255.	Capscrew
118.	Plug Gasket	256.	Capscrew Gasket
119.	Oil Pump Package	257.	Oil Filter
120.	Pump Cover Gasket	258.	Oil Filter Bracket
121.	Bearing Head Gasket	259.	Control Bracket Stud
122.	Pump End Gasket	260.	Pressure Control Bracket
123.	Pump End Cover and Control Valve Assy.	261.	Pressurestat



COMPRESSOR/CONDENSING UNITS

5H FREON

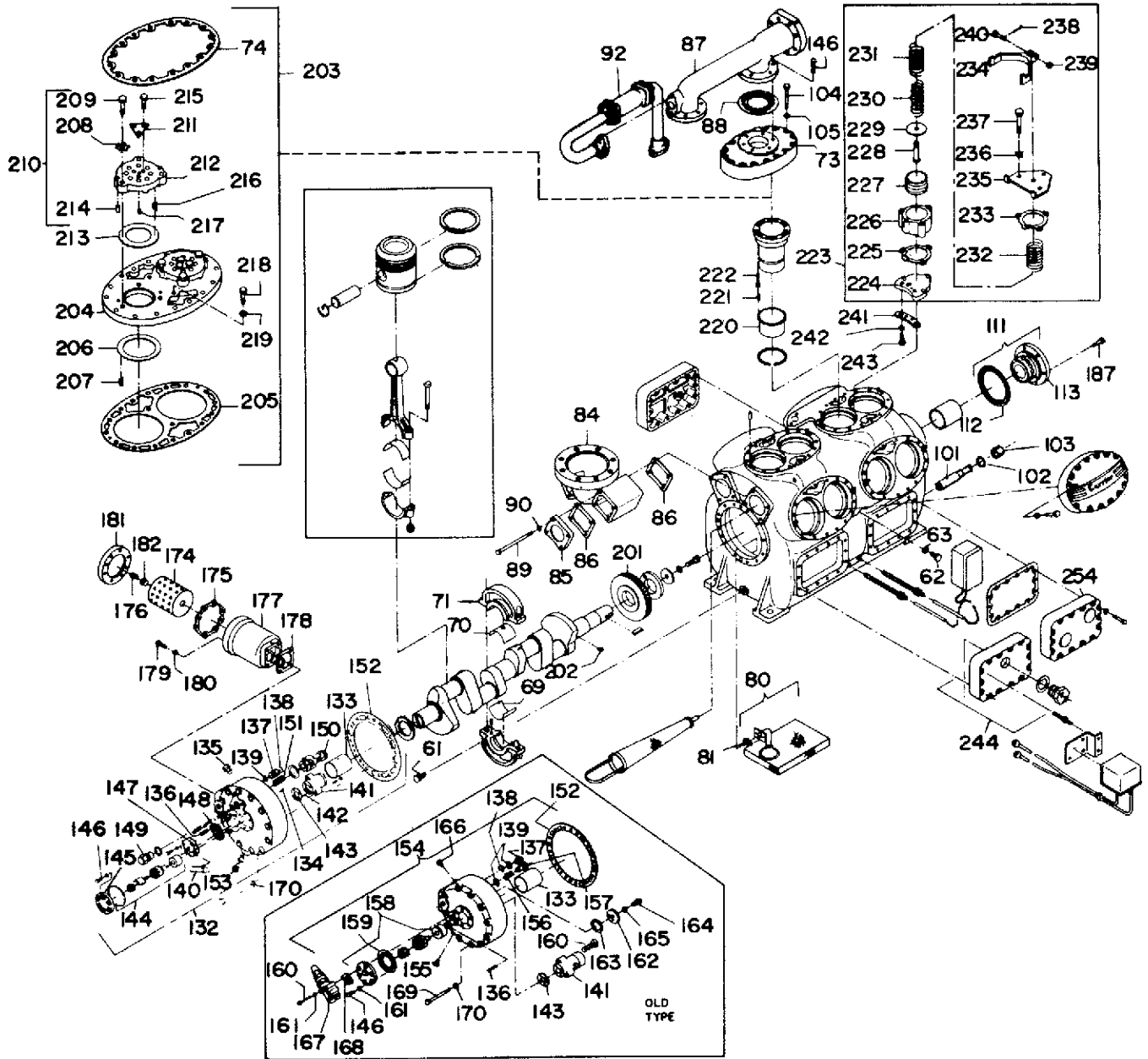

COMPRESSOR
(5H120 shown)



COMPRESSOR/CONDENSING UNITS

5H

FREON

LEGEND 5H120

ITEM NO.	PART NAME	ITEM NO.	PART NAME
61.	Heater Casing and Adapter Gasket	165.	Capscrew Gasket
62.	Oil By-Pass Plug	166.	Oil By-Pass Plug
63.	Plug Gasket	167.	Capacity Control Valve Package
64.	Crankcase Heater Element	168.	Control Valve Gasket
69.	Center Bearing	169.	Capscrew
70.	Center Bearing, Top Half	170.	Capscrew Gasket
71.	Center Bearing, Housing	174.	Oil Filter Cartridge
73.	Cylinder Head, Centerbank	175.	Oil Filter Cover Gasket
80.	Oil Screen and Suction Tube Assembly	176.	Oil Filter Spring
81.	Oil Suction Tube Gasket	177.	Oil Filter Housing
84.	Suction Manifold	178.	Oil Filter Housing Gasket
85.	Suction Manifold Cover	179.	Socket Head Capscrew
86.	Suction Manifold and Cover Gasket	180.	Capscrew Gasket
87.	Discharge Manifold	181.	Oil Filter Cover
88.	Discharge Manifold Gasket	182.	Oil Filter Spring Retainer
89.	Hex Head Capscrew	201.	Oil Recovery Impeller
90.	Capscrew Gasket	202.	Dowel Pin
92.	Pressure Relief Valve	203.	Valve Plate Package
101.	Oil Pressure Regulator Valve	204.	Valve Plate
102.	Regulator Valve Gasket	205.	Valve Plate Gasket
103.	Regulator Valve Cap	206.	Suction Valve
104.	Cylinder Head Capscrew	207.	Suction Valve Spring
105.	Capscrew Gasket	208.	Lockwasher
111.	Replacement Seal Package	209.	Screw
112.	Cover Plate Gasket	210.	Discharge Valve Guide
113.	Carbon Washer	211.	Lockplate
132.	Bearing Head and Oil Pump Assembly	212.	Guide
133.	Main Bearing	213.	Discharge Valve
134.	Grove Pin	214.	Discharge Valve Spring
135.	Adapter Plug	215.	Screw
136.	Control Oil Strainer	216.	Dowel Pin 3/16"
137.	Oil Filter By-Pass Spring	217.	Dowel Pin 1/4"
138.	By-Pass Retaining Ring	218.	Capscrew
139.	Valve Disc, By-Pass and Equalizer	219.	Capscrew Gasket
140.	Angle Valve	220.	Unloader Sleeve
141.	Hydraulic Relay	221.	Valve Lifter Spring
142.	Dowel Pin	222.	Valve Lifter Pin
143.	Hydraulic Relay Gasket	223.	Unloader Power Element Assembly
144.	Oil Pump Package	224.	Unloader Cylinder Bracket
145.	Oil Pump Cover	225.	Unloader Cylinder Gasket (Bottom)
146.	Capscrew	226.	Unloader Cylinder
147.	Oil Flow Cap	227.	Unloader Piston
148.	Oil Flow Cap Gasket	228.	Unloader Piston Rod
149.	External Valve Assembly	229.	Unloader Spring
150.	Valve Body with Bellows	230.	Unloader Spring
151.	Spring	231.	Unloader Spring
152.	Bearing Head Gasket	232.	Unloader Spring
153.	Seal Plug	233.	Unloader Cylinder Gasket (Top)
154.	Bearing Head and Oil Pump Assembly	234.	Unloader Fork
155.	Socket Head Pipe Plug	235.	Cylinder Cover Plate Assembly
156.	Equalizer Valve Spring	236.	Lockwasher
157.	Equalizer Valve Seat	237.	Capscrew
158.	Oil Pump Package	238.	Cotter Pin
159.	Pump Cover Gasket	239.	Plate Washer
160.	Socket Head Capscrew	240.	Clevis Pin
161.	Capscrew Gasket	241.	Unloader Bracket Gasket
162.	Surge Cover	242.	Socket Head Capacity
163.	Surge Cover Gasket	243.	Lockwasher 5/16"
164.	Capscrew	244.	Hand Hole Cover and Sight Glass Assembly
		254.	Hand Hole Cover for Interconnection



COMPRESSOR/CONDENSING UNITS

5H

FREON

ITEM NO.	PART NAME	LDC	REPLACEMENT PART NUMBER	UNIT USAGE							
				5H							
				40	46	60	66	80	86	120	126

COMPRESSOR BODY GROUP

NI	Gasket Set	AC	5H40-502	1	1						
		AC	5H60-502			1	1				
		AC	5H80-502					1	1		
		AC	5H120-502							1	1
56	Crankcase Assembly	NA	5H40-124	1	1						
		NA	5H60-124			1	1				
		NA	5H80-129					1			
		NA	5H86-129						1		
	Each Includes:										
57	Main Bearing (1) 5H40-1012	AC									
58	Groove Pin (Bearing Washer) (1) AX35HR-120-012	PT									
59	Crankcase Heater Casing 1 Required on 5H40-66 2 Required on 5H80-86 (Check Depth of Heater Casing to Select Proper Replacement)										
	3-1/2 Deep 5F40-3742	AC									
	4-3/8 Deep 5H40-3992	NS									
	7-3/8 or 8-5/16 Deep 5F20-3742	AC									
60	Dowel Pin (Valve Plate) 1 per Cylinder AX11AR-197-020	PT									
NI	Adapter (Oil Filter (1) 5F20-1311	AC									
	or Plug (1) 5H40-1141	AC									
61	Heater Casing and Adapter Gasket										
	5H40-66 (2) AU51YA-011-012	PT									
	5H80-86 (3) AU51YA-011-012	PT									
NI	Tube Ferrule 3/16 on 5H40-46 (6) 5H40-1531	AC									
	on 5H60-86 (8) 5H40-1531	AC									
NI	Tube Ferrule 1/4 on 5H80-86 (2) 5H40-1541	AC									
	Tube Ferrule 3/8 on 5H40-86 (2) 5H81-1551	AC									
NI	Hollow Setscrew (80-86) (1) AF20AA-313-005	PT									
NI	Setscrew (80-86) (1) BE72AR-320	NS									
	Oil Supply Tubing 5H40-46										
	Includes:										
NI	Oil Suction Tube (1) 5H40-772	AC									
NI	Oil Tube to Cyl. 1L (1) 5H40-1953	AC									
NI	Oil Tube to Cyl. 2R (1) 5H40-1943	AC									
NI	Oil Tube to Cyl. 1R (1) 5H40-1163	AC									
NI	Seal End Brg. Supply (1) 5H40-1342	AC									
NI	Oil Supply Tubing 5H60-66										
	Includes:										
NI	Oil Suction Tube (1) 5H40-772	AC									
NI	Oil Tube to Cyl. 1L (1) 5H60-1133	AC									
NI	Oil Tube to Cyl. 2L (1) 5H60-1143	AC									
NI	Oil Tube to Cyl. 2R (1) 5H60-1153	AC									
NI	Oil Tube to Cyl. 1R (1) 5H60-1163	AC									
NI	Seal End Brg. Supply (1) 5H60-1342	AC									
	<p>NOTE: Cylinder identification is done by looking at Compressor from Pump End. Ex: On 5H120 3L is 3rd Cylinder from Pump End on Left Hand Cylinder Bank.</p>										



COMPRESSOR/CONDENSING UNITS

5H
FREON

ITEM NO.	PART NAME	LDC	REPLACEMENT PART NUMBER	UNIT USAGE							
				5H							
				40	46	60	66	80	86	120	126

COMPRESSOR BODY GROUP (CONT'D.)

NI	Oil Supply Tubing 5H80-86 Includes:										
NI	Oil Suction Tube (1) 5H40-772	AC									
NI	Oil Tube to Cyl. 1R (1) 5H80-1823	AC									
NI	Oil Tube to Cyl. 2R (1) 5H80-1833	AC									
NI	Oil Tube to Cyl. 1L and 2L (1) 5H80-343	AC									
NI	Oil Tube to Cyl. 3L and 4L (1) 5H80-853	AC									
NI	Seal End Brg. Supply 5H80 Only (1) 5H81-1342	AC									
NI	Pump End to Ctr. Brg. 5H86 Only (1) 5H86-102	AC									
NI	Center Brg. to Seal End 5H86 Only (1) 5H86-112	AC									
NI	Center Brg. Elbow (1) DD10CA-103	AC									
56	Crankcase Assembly Includes:	NA	5H120-129							1	
		NA	5H126-129								1
57	Main Bearing, Seal End (1) 5H40-1012	AC									
58	Roll Pin (Brg. Washer) (1) AX14CA-222	AC									
60	Dowel Pin (Valve Plate) (12) AX11AR-197-020	PT									
59	Crankcase Heater Casing (Check Depth of Heater Casing to Select Proper Replacement)										
	3-1/2 Deep (2) 5F40-3742	AC									
	4-3/8 Deep (2) 5H40-3992	AC									
	7-3/8 or 8-5/16 Deep (2) 5F20-3742	AC									
61	Magnetic Plug (1) CA99AA-101	AC									
62	Seal Plug (1) 5H120-2181	NS									
63	Gasket (2) AU51YA-013-020	PT									
NI	Hollow Setscrew (1) AF20AA-313-005	PT									
NI	Setscrew (1) BE72AR-320	NS									
NI	Oil By-Pass Plug (2) 5H40-1141	AC									
NI	Plug & Htr. Gasket (4) AU51YA-011-012	PT									
NI	Tube Ferrule 1/4 (8) 5H120-4502	AC									
NI	5/16 (4) 5H120-4512	AC									
NI	5/8 (1) 5H120-4522	AC									
NI	3/8 (1) 5H81-1551	AC									
NI	Oil Tube to Cyl. 3L & 4L (1) 5H120-524	AC									
NI	3C & 4C (1) 5H120-813	AC									
NI	3R & 4R (1) 5H120-823	AC									
NI	3L & 4L (1) 5H120-2173	AC									
NI	3C & 4C (1) 5H120-2133	AC									
NI	3R & 4R (1) 5H120-2113	AC									
NI	5H120 Only 1L & 1R (1) 5H120-514	AC									
NI	5H120 Only 3R & 4R (1) 5H120-823	AC									
NI	5H126 Only 1L & 1R (1) 5H126-134	AC									
NI	5H126 Only 3R & 4R (1) 5H126-113	AC									
NI	Pump End to Center Tee (1) 5H120-4602	AC									
NI	Center Tee to Seal End (1) 5H120-4612	AC									
NI	Center Tee to Ctr. Brg. (1) 5H120-972	AC									
NI	Equalizer Line (Seal End (Seal End) (1) 5H120-833	AC									
NI	Ermeto Union 5/16 (3) DC06SA-076	AC									
NI	Ermeto Union Tee 5/8 (1) DC18SA-301	AC									
NI	Ermeto Reducer 5/8 x 1/2 (1) DC04SA-302	AC									
NI	Elbow 3/8 FL x 1/4 MPT (2) DD10CA-103	AC									



COMPRESSOR/CONDENSING UNITS

5H
FREON

ITEM NO.	PART NAME	LDC	REPLACEMENT PART NUMBER	UNIT USAGE							
				5H							
				40	46	60	66	80	86	120	126
COMPRESSOR BODY (CONT'D.)											
64	Crankcase Heater Element PSN F7 6/77										
	115V, 200W, 6" Long	AC	HT31AR-200	1	1	1	1	2	2	2	2
	230V, 200W, 6" Long	AC	HT31AR-230	1	1	1	1	2	2	2	2
	(Used in Well 5F20-3742)										
	115V, 100W, 3-1/8" Long	AC	HT31AR-100	1		1		2		2	
	230V, 100W, 3-1/8" Long	AC	HT31AR-130	1		1		2		2	
	(Used in Well 5F40-3742 and 5H40-3992)										
	SSN F7 6/77										
	115V, 200W, 8-1/4" Long	AC	HT31AZ-121	1	1	1	1	2	2	2	2
	230V, 200W, 8-1/4" Long	AC	HT31AZ-241	1	1	1	1	2	2	2	2
	(Used in Well 5F20-3742)										
NI	Heater Coupling (1" Conduit)	AC	HW25FA-005	1	1	1	1	2	2	2	2
65	Crankcase Heater Relay 115V, 60 Hz 208/230V, 50/60 Hz	AC	HN61AJ-101	1	1	1	1	1	1	1	1
		AC	HN61AJ-108	1	1	1	1	1	1	1	1
NI	Oil Return Check Valve Includes:	AC	5H40-932	2	2	2	2	2	2		
66	Check Valve	NSS									
67	Check Valve Gasket (1) 5H40-1171-012	PT									
68	Machine Screw w/Washer #12-24 1/2" Long	PT	AC73AA-146-020	4	4	4	4	4	4		
NI	Cover, Gas Equalizer Connection	AC	5H120-4432							1	1
NI	Gasket, Gas Equalizer Connection	PT	7K4-4522-012							1	1
69	Center Bearing, Half	AC	5H80-1242					2	1	1	1
70	Center Bearing Top Half	AC	5H120-1242						1	1	1
71	Center Bearing Housing	AC	5H80-204					1			
		AC	5H120-204						1	1	1
72	Cylinder Head	AC	5H60-1004	2	2	3	3	4	4	4	4
73	Cylinder Head, Center Bank	AC	5H120-1004							2	2
74	Cylinder Head Gasket	PT	5H40-1093-010	2	2	3	3	4	4	6	6
NI	Water Cooled Cylinder Head Pkg. (Obtain from Finished Goods)	NA	5H40-507	1	1						
		NA	5H60-507			1	1				
		NA	5H80-507					1	1		
		NA	5H120-507							1	1



COMPRESSOR/CONDENSING UNITS

5H

FREON

ITEM NO.	PART NAME	LDC	REPLACEMENT PART NUMBER	UNIT USAGE							
				5H							
				40	46	60	66	80	86	120	126

COMPRESSOR BODY (CONT'D.)

	Each Includes:	LDC	REPLACEMENT PART NUMBER	INCLUDED ON			
				5H40 507	5H60 507	5H80 507	5H120 507
NI	Cylinder Head	AC	5H41-1019	2	3	4	6
NI	Cylinder Head, Center	AC	5H121-1019				2
NI	Cylinder Head Gasket	PT	5H40-1093-010	2	3	4	6
NI	Cylinder Head Cover	AC	5H61-1039	2	3	4	4
NI	Cyl. Head Cover Center Left S.E.	AC	5H121-1434				1
NI	Cyl. Head Cover Center Right S.E.	AC	5H121-1424				1
NI	Cyl. Head Cover Center Left P.E.	AC	5H121-1044				1
NI	Cyl. Head Cover Center Right P.E.	AC	5H121-1054				1
NI	Cylinder Head Cover Gasket	AC	5H41-1703	2	3	4	4
NI	Cylinder Head Cover Gasket, Center	AC	5H121-1703				4
NI	Hex Head Capscrew, 3/8-16 x 1-1/4 Lg.	PT	AA06BR-232-012	32	48	64	72
NI	Hex Head Capscrew 7/16-14 x 4-1/4 Lg.	PT	AA06BR-274-010	32	48	64	64
NI	Hex Head Capscrew 7/16-14 x 5-1/8 Lg.	AC	AA06BR-977				32
NI	Hex Head Capscrew 3/8-16 x 1-1/2 Lg.	PT	AA06BR-233-012				32
NI	Half Union Elbow 5/8 FL x 1/2 MPT	AC	DD10CA-302	1	4	4	12
NI	Half Union Coupling	AC	DD07DA-302	1		2	
NI	Half Union Elbow 1/2 FL x 3/8 MPT	AC	DD10CA-203				2
NI	Discharge Manifold Gasket	AC	5H120-4472				2
NI	Discharge Valve Gasket	PT	5H80-1632-012				1
NI	Relief Valve Gasket	PT	7K4-4522-012				3
NI	Flange Spacer	AC	5H120-5952				1
NI	Hex Head Capscrew 1/2-13 x 2" Lg.	AC	AA06BR-295				2
75	Suction Strainer Assembly	AC	5H40-323	1	1		
		AC	5H60-132		2	2	
		AC	5H80-323			1	1
		AC	5H120-794				2 2
76	Suction Strainer Gasket	AC	5H40-1361	1	1		
		AC	5H60-1831		2	2	
NI	Suction Filter Package	AC	5H40-A382	1	1		
		AC	5H60-A382		1	1	
		AC	5H80-A382			1	1
		AC	5H120-A382				1 1
NI	Includes: Felt Filter on 5H40 (1) 5H40-4032 5H60 (2) 5H60-4032 5H80 (1) 5H80-4032 5H120 (2) 5H120-4552	AC					
77	Cylinder Sleeve (With Holes) (Use in place of Sleeves w/o Unloader Pin Holes)	AC	5H40-1003	4	6	8	12
		AC	5H46-1003	4	6	8	12
78	Cylinder Sleeve Snap Ring	AC	5H40-2221	3	3	4	4
				6	6	8	8
79	Oil Screen Package	AC	5H40-237	1	1	1	1
	Includes: Oil Screen Gasket (2) 5H40-1371	AC					
80	Oil Screen and Suction Tube Assembly	AC	5H120-252				1 1
81	Oil Suction Tube Gasket	AC	5H120-3451				1 1



COMPRESSOR/CONDENSING UNITS

5H
FREON

ITEM NO.	PART NAME	LDC	REPLACEMENT PART NUMBER	UNIT USAGE								
				5H								
				40	46	60	66	80	86	120	126	
COMPRESSOR BODY GROUP (CONT'D.)												
NI	Suction and Discharge Manifold (For 4 Bolt Valve)	AC	5H60-1714				2	2				
NI	Manifold Gasket	PT	5H60-1681-012				4	4				
82	Suction and Discharge Manifold Cover	AC	5H40-1052	1	1				1	1		
83	Manifold Cover Gasket	AC	5H40-1032	1	1				1	1		
NI	Suction Manifold Cover Plate	AC	5H80-1892						1	1		
NI	Suction Manifold and Disch. Valve Gasket	PT	5H60-1632-012						2	2		
84	Suction Manifold (For 4 Bolt Valve) (8 Bolt Valve Manifold N/A)	AC	5H120-1299								1	1
85	Suction Manifold Cover	NS	5H120-4452								2	2
86	Suction Manifold and Cover Gasket	AC	5H120-4462								4	4
87	Discharge Manifold (For 4 Bolt Valve) (8 Bolt Valve Manifold N/A)	AC	5H120-1279								1	1
88	Discharge Manifold Gasket	AC	5H120-4472								2	2
NI	Suction and Discharge Manifold Mounting Bolts (1/2-13 x 4 Lg.)	AC	AA06BR-303				16	16				
89	Suction Manifold Mounting Bolts (5/8-11 x 6-1/2 Lg.)	NS	AH06BR-340								8	8
90	Capscrew Gasket 1/2 5/8 (Not Used on Current Production)	PT PT	AU51YA-009-012 AU51YA-011-012						16	16	8	8
NI	Manifold Cover Plate (Top of Crankcase Between Valves)	AC	7J1-6002						1	1		
NI	Cover Plate Gasket	PT	6D40-1061-012						1	1		
91	Internal Relief Valve - 300 Psi	AC	EB51FH-270	1	1	1	1	1	1	1		
92	Discharge Pressure Relief Valve Assy. Includes: Valve (1) EB51FN-870 Gasket (2) EP29YC-360	AC AC AC	5H120-337								1	1
NI	Relief Valve Line Gaskets	PT	7K4-4522-012								2	2
∅Parts for Adjustable Oil By-Pass Valve												
93	Oil By-Pass Plug	AC	5H40-1141	1	1	1			1			
94	Oil By-Pass Plug Gasket	PT	AU51YA-011-012	1	1	1			1			
95	Oil By-Pass Lockscrew 5/8-18 x 5/16 Lg.	PT	AF20AA-313-005	1	1	1			1			
96	Oil By-Pass Adjusting Screw	AC	5H40-1121	1	1	1			1			
97	Oil By-Pass Spring	AC	7K3-4182	1	1	1			1			
98	Oil By-Pass Valve	AC	5H40-1111	1	1	1			1			



COMPRESSOR/CONDENSING UNITS

5H
FREON

ITEM NO.	PART NAME	LDC	REPLACEMENT PART NUMBER	UNIT USAGE							
				5H							
				40	46	60	66	80	86	120	126
COMPRESSOR BODY GROUP (CONT'D.)											
99	ØNon-Adjustable Oil Pressure Regulator Pkg. Includes:	AC	5H40-962	1	1	1	1	1	1		
100	Gasket (1) AU51YA-011-012	PT									
101	Regulator Valve (1) 5H40-782	NSS									
103	Regulator Valve Cap (1) 5H40-3982	AC									
	Ø NOTE: The Non-Adjustable Oil Pressure Regulator is a replacement for the Adjustable Oil By-Pass Valve Parts.										
101	Oil Pressure Regulator Valve	AC	5H120-782							1	1
102	Regulator Valve Gasket	PT	AU51YA-013-012							1	1
103	Regulator Valve Cap	AC	5H120-3381							1	1
104	Cylinder Head Bolt (7/16-14 x 3-1/2 Lg.)	PT	AA06BR-271-020	32	32	48	48	64	64	96	96
105	Capscrew Gasket 7/16 (Not Used on Current Production)	PT	AU51YA-008-012	38	38	48	48	134	134	182	182
106	Angle Valve (to Oil Filter)	AC	EP23LC-090	2	2	2	2	2	2		
SEAL END GROUP											
107	Replacement Seal Package Rotary Sleeve Type Includes:	AC	5H40-276	1	1	1	1	1	1		
108	Cover Plate Gasket (1) 5H40-3692	AC									
109	#Carbon Washer (1) 5HD-1258-A	NSS									
110	Cover Plate w/o Integral Seat Seal (1) 5H40-2433	AC									
111	Replacement Seal Package Rotary Sleeve Type Includes:	AC	5H120-732							1	1
112	Cover Plate Gasket (1) 5H40-3692	AC									
109	#Carbon Washer (1) 5HD-1258-A	NSS									
113	Cover Plate w/o Integral Seat Seal (1) 5H40-2433	AC									
	# NOTE: Replacement only for washers damaged in shipping or installation. Do not replace on seals that have been in operation.										
	The Rotary Sleeve type seal can be used as a replacement for either the early stationary or rotary bellows type.										
114	Seal Cover Plate Capscrew	PT	AA06BR-262-012	6	6	6	6	6	6	6	6
NI	Shaft Seal Cover Plate (For Early Rotary Bellows Type Seal)	NA	5H40-3882	1		1		1			
NI	Cover Plate Gasket (For Early Rotary Bellows Type Seal)	AC	5H40-1181	1		1		1			



COMPRESSOR/CONDENSING UNITS

5H
FREON

ITEM NO.	PART NAME	LDC	REPLACEMENT PART NUMBER	UNIT USAGE							
				5H							
				40	46	60	66	80	86	120	126
PUMP END GROUP											
115	Bearing Head and Oil Pump Assembly (Drilled for Oil Cooler) Includes:	AC	5H40-677	1	1	1	1	1	1		
116	Main Bearing (1) 5H40-1022	AC									
117	Magnetic Plug (1) CA99AA-101	AC									
118	Plug, Gasket (1) AU51YA-011-012	PT									
NI	Capscrew 1/4-28 x 3/4 (Oil Pump Cover) (4) AB06BR-168-012	PT									
NI	Groove Pin (Brg. Washer) (1) AX35HR-120-012	PT									
NI	Sleeve (w/Oil Cooler) (1) 5H40-7252	AC									
119	Oil Pump Package (Matched Parts) (1) 5H40-A372 Includes:	AC									
	Cover, Idler, Rotor and Bushing	NSS									
120	Pump Cover Gasket (1) 5F40-1211-012	PT									
121	Bearing Head Gasket (1) 5H40-1113-012	PT									
122	Pump End Gasket (1) 5H40-1423	AC									
123	Pump End Cover and Control Valve Assembly Includes:	AC	5H40-A564	1	1	1	1	1	1		
122	Pump End Cover Gasket (1) 5H40-1423	AC									
NI	Hydraulic Relay (Aux. Control Valve) (1) 5F40-767	AC									
NI	Oil By-Pass lug (2) 5H40-1141	AC									
NI	Control Oil Stariner (1) 5H40-1971	AC									
NI	Socket Head Capscrew 5/16-24 x 1 (2) AB44AA-704	AC									
NI	Hollow Lock Screw (1) AF20AA-313-005	PT									
NI	Capscrew Gasket (2) AU51YA-004-012	PT									
NI	Capscrew Gasket (2) AU51YA-011-012	PT									
124	Control Valve Package (1) 5F40-721 Includes:	AC									
125	External Valve Assy. (1) 5F-88213	AC									
126	Bellows Assembly (1) 05HG660014	AC									
127	7 lb. Spring (R12,500) (1) 5F-88206	AC									
NI	11 lb. Spring (R22) (1) EB39CZ-001	AC									
128	Valve Gasket Inner (1) 5H40-2001-012	PT									
129	Valve Gasket Outer (1) 5H40-1411-012	PT									
130	Socket Head Capscrew 1/2"-13 x 3	PT	AA44AA-299-010	12	12	12	12	12	12	12	12
131	Capscrew Gasket 1/2"	PT	AU51YA-009-012	12	12	12	12	12	12	12	12
132	Bearing Head and Oil Pump Assembly Starting Serial #0447119 Includes:	AC	5H120-837							1	1
NI	Sleeve (For Oil Cooler Application) (1) 5H40-7252	AC									
133	Main Bearing (1) 6L80-2172	AC									
134	Groove Pin (1) AX35HR-120-012	PT									
135	Adapter Plug (1) 6G40-1451	AC									
NI	Plug Gasket (1) AU51YA-011-012	PT									
NI	Socket Head Pipe Plug (5) CA64AA-001	AC									
136	Control Oil Strainer (1) 5H120-3301	AC									
NI	Cover, Surge Chamber (1) 6L45-1041	NS									
NI	Gasket, Chamber Cover (1) 5H120-3341-012	PT									
NI	Capscrew 3/8"-16 x 4" (1) _____	NA									
NI	Capscrew Gasket (1) AU51YA-005-012	PT									
137	Oil Filter By-Pass Spring (1) 5H120-1683	AC									



COMPRESSOR/CONDENSING UNITS

5H
FREON

ITEM NO.	PART NAME	LDC	REPLACEMENT PART NUMBER	UNIT USAGE						
				5H						
				40	46	60	66	80	86	120

PUMP END GROUP (CONT'D.)

132	Bearing Head and Oil Pump Assembly (Cont'd.) Includes:																	
138	By-Pass Retaining Ring	(1)	AU47AR-087	NA														
139	Valve Disc: By-Pass and Equalizer	(2)	5H120-3411	AC														
NI	Equalizer Valve Spring	(1)	5H120-1593	AC														
NI	Equalizer Valve Seat	(1)	5H120-3401	AC														
140	Angle Valve	(1)	EP23QA-090	AC														
141	Hydraulic Relay (Auxiliary Control Valve Assembly)	(1)	6L45-123	AC														
	Includes:																	
NI	Cover Gasket	(1)	5H120-3361-012	PT														
NI	Ball 3/16" O.D.	(2)	KT37ZZ-013	AC														
142	Dowel Pin 1/8 x 1/2 Lg.	(2)	AX11AR-062-010	PT														
143	Hydraulic Relay Gasket	(1)	5H120-3351-012	PT														
NI	Socket Head Screw	(2)	AA44AA-206	AC														
144	Oil Pump Package (For Current 5 H120-837 Pkg.) (Matched Parts)	(1)	5H120-A773	AC														
	Includes:																	
NI	Oil Pump Cover Gasket	(1)	5H120-3891	AC														
144	Oil Pump Package (For Former 5H120-747 Pkg.)	(1)	06LA660008	AC														
	Includes:																	
NI	Idler, Bushing and Rotor Pump Cover O-Ring	(1)	KK71CY-033	AC														
145	Oil Pump Cover (For 5H120-837)	(1)	5H120-2923	NS														
	(For 5H120-747)	(1)	5H120-6422	AC														
146	Capscrew 5/16-18 x 1	(6)	AA06BR-200-012	PT														
147	Oil Flow Cap	(1)	6L45-1122	NA														
148	Oil Flow Cap Gasket	(1)	6L45-1132	AC														
NI	Capscrew Gasket (Oil Flow Cap and Oil Pump Cover)	(10)	AU51YA-003-012	PT														
NI	Capacity Control Valve	(1)	5F40-721	AC														
	Includes:																	
149	External Valve Assy.	(1)	5F-88213	AC														
150	Bellows	(1)	05HG660014	AC														
151	7 lb. Spring (RR,R500)	(1)	5F-88206	AC														
151	11 lb. Spring (R22)	(1)	EB39CZ-001	AC														
NI	Valve Gasket (Inner)	(1)	5H40-2001-012	PT														
	(Outer)	(1)	5H40-1411-012	PT														
NI	Socket Head Screw	(2)	AA44AA-206	AC														
NI	Capscrew Gasket	(2)	AU51YA-004-012	PT														
152	Bearing Head Gasket	(1)	5H120-1653	AC														
153	Seal Package	(1)	5H120-3821	NS														
NI	Gasket	(1)	AU51YA-003-012	PT														



COMPRESSOR/CONDENSING UNITS

5H
FREON

ITEM NO.	PART NAME	LDC	REPLACEMENT PART NUMBER	UNIT USAGE						
				5H						
				40	46	60	66	80	86	120
PUMP END GROUP (CONT'D.)										
154	Bearing Head and Oil Pump Assembly Prior to Serial #0447119 (with external Capacity Control Valve) Includes:	NA								
133	Main Bearing	AC	-5-H--40--1022--						1	1
155	Socket Hd. Pipe Plug 1/8"	AC	--CA--64AA-001--						4	4
137	Oil Filter By-Pass Spring	AC	-5-H-120--1683--						1	1
138	By-Pass Retaining Ring	AC	--AU--47AA-087--						1	1
139	Valve Disc, By-Pass and Equalizer Valve	AC	-5-H-120--3411--						2	2
156	Equalizer Valve Spring	AC	-5-H-120--1593--						1	1
157	Equalizer Valve Seat	AC	-5-H-120--3401--						1	1
158	Oil Pump Pkg. (Matched Parts) Includes: Cover, Idler, Rotor and Bushing	AC	06LA-660---008--						1	1
159	Pump Cover Gasket	AC	-5-H-120--3431--						1	1
152	Bearing Head Gasket	AC	-5-H-120--1653--						1	1
136	Control, Oil Strainer	AC	-5-H-120--3301--						1	1
146	Capscrew 5/16-18 x 1	NA	--AA--44BR-200--						6	6
160	Socket Head Capscrew	AC	--AA--44AA-206--						6	6
161	Capscrew Gasket	MP	--AU--51YA-004--						10	10
162	Surge Cover	NA	-5-H-120--3331--						1	1
163	Surge Cover Gasket	MP	-5-H-120--3341--						1	1
164	Capscrew 3/8-16 x 4	NA							1	1
165	Capscrew Gasket	MP	--AU--51YA-005--						1	1
166	Oil By-Pass Plug	AC	-5-H--40--1141--						1	1
143	Hydraulic Relay Gasket	MP	-5-H-120--3351--						1	1
141	Hydraulic Relay (Auxiliary Control Valve) Includes:	AC	-6-L--45---123--						1	1
NI	Cover Gasket	MP	-5-H-120--3361--						1	1
NI	Ball 3/16" O.D.	AC	--KT--37ZZ-013--						2	2
167	Capacity Cont. Valve Pkg Includes:	NA	-5-H-121---417--						1	1
168	Control Valve Gasket	AC	-5-H-120--4642--						1	1
NI	Range Spring R12	AC	--EM--99AS-100--						1	1
NI	Range Spring R22	AC	--EM--99AS-120--						1	1
169	Capscrew 1/2-13 x 4-1/4 Lg.	AC	--AA--06BR-304--						12	12
170	Capscrew Gasket 1/2"	MP	--AU--51YA-009--						12	12
171	Double Branch Angle Valve++	AC	--P--32TA-150--	1	1	1	1	1	1	1
172	Angle Valve 1/4 x 1/4++	AC	--EP--23LC-090--	1	1	1	1	1	1	1
173	Oil Pressure Gauge (0-200#)++ ++ NOTE: PSN D707060 parts are standard. SSN D707060 parts are only included if Oil Filter Pkg. was installed. Shipping, Storage Valves on current units should be removed and connections plugged.	AC	--KM--01BC-200--	2	2	2	2	2	2	2
NI	Pipe Plug 1/4"	AC	--CA--63AA-051--	2	2	2	2	2	2	2



COMPRESSOR/CONDENSING UNITS

5H

FREON

SERVICE OIL PUMP PACKAGE HISTORY CHART

	<u>5H120-A372</u>	<u>06LA660008</u>	<u>5H120-A773</u>
Compressor	5H120	5H120/126	5H120/126
Date Manufactured	Prior 1960	1960-1968	Starting 1969
Serial Number Break	Prior 0447119 (See Note Below)	Starting 0447119 To A901765	Starting A901765
Oil Pump	Tuthill-Gear (Idler Pin Part of Cover Assy.)	Spenex-Gear Rotor	Gear Rotor (See Fig. 16-5F,H-2SS Start-Up and Service Instructions)
I.D. Bearing Head (@ Pump)		1-3/4"	2-3/16"
Package Consists of:	5H120-150 Pump Assembly 5H120-3431 Pump Cover Gasket 5H120-1653 P.E. Brg. Hd. Gskt 5F20-3511 Instruction Sheet 5F20-1271 Warning Tag	6L120-397 Pump Assy. (2) 6L120-2672 Gasket 6L120-2632 Adapter 1/2 Thk.	5H120-A773 Pump Assy.

NOTE: Prior to this Serial Number, the 5H120 Bearing Head did not have the Capacity Control Valve and Adjusting Stem as part of its assembly.



COMPRESSOR/CONDENSING UNITS

5H

FREON

ITEM NO.	PART NAME	LDC	REPLACEMENT PART NUMBER	UNIT USAGE							
				5H							
				40	46	60	66	80	86	120	126

PUMP END GROUP (CONT'D.)

174	Oil Filter Cartridge Package	AC	5H120-351								1	1
	Includes:											
175	Oil Filter Cover Gskt (1) 5H120-4492	AC										
	Oil Filter Cartridge (1) KH09TC-120	NSS										
176	Oil Filter Spring	AC	5H120-1643								1	1
177	Oil Filter Housing	AC	5H120-1334								1	1
178	Oil Filter Housing Gasket	AC	5H120-4482								1	1
179	Socket Head Capscrew 1/2-16 x 1/4	PT	AA44AA-292-010								4	4
180	Capscrew Gasket 1/2	PT	AU51YA-009-012								4	4
181	Oil Filter Cover	AC	5H80-1892								1	1
182	Oil Filter Spring Retainer	AC	5H120-3441								1	1

On Units produced before July 1973, a complete Capacity Control Valve Pkg (Part #5F40-721) is required. This package contains Inner and Outer Seal Gaskets (5H40-2001 and 5H40-1411). On Units manufactured after July 1973, the Bellows Assembly can be replaced by itself, if desired. The Part Number for the Bellows Package is 05HG660014. When using this Bellows Assembly, you must also use (1) 5H40-1411 (Outer Seal Gasket) and (1) 5H40-2001 (Inner Seal Gasket). These Gaskets aren't included with the Bellows Assembly and both are sold in packages of 12.

CRANKSHAFT AND PISTON GROUP

183	Crankshaft Assembly	AC	5H40-562	1								
		AC	5H46-114		1							
		AC	5H60-114			1						
		AC	5H66-562				1					
		AC	5H80-562					1				
		AC	5H86-562						1			
		AC	5H120-562								1	
		AC	5H126-562									1
184	Flywheel Drive Key	AC	5H40-2851	1	1	1	1	1	1	1	1	1
185	Flywheel Washer	AC	5H40-1401	1	1	1	1	1	1	1	1	1
186	Flywheel Lockwasher	PT	AU29AR-331-012	1	1	1	1	1	1	1	1	1
187	Flywheel Capscrew 5/8-18 x 1-1/2	PT	AB06BR-323-010	1	1	1	1	1	1	1	1	1
188	Connecting Rod Package (Steel Rod) SSN F701597 (See Note #2 on Pg. 59)	AC	5H40-103	4		6		8		12		
		AC	5H40-103		4		6		8			12
	Includes:											
189	Connecting Rod Bolt (2) 5H40-1041	AC										
190	Connecting Rod Nut (2) AT61AA-272-010	PT										
	Connecting Rod (1) 5H40-1293	NSS										
NI	Piston Pin Bushing (1) 5H40-1031	NSS										
NI	Connecting Rod Bearing Package SSN F701597	AC	5H40-451	2		3		4		6		
		AC	5H40-451		2		3		4			6
	Includes:											
191	Connecting Rod Bearing Half (4) 5H40-1002	NSS										
	(Conn. Rod Brgs. not req'd on alum. rods.)											



COMPRESSOR/CONDENSING UNITS

5H

FREON

ITEM NO.	PART NAME	LDC	REPLACEMENT PART NUMBER	UNIT USAGE							
				5H							
				40	46	60	66	80	86	120	126

CRANKSHAFT AND PISTON GROUP (CONT'D.)

188	Connecting Rod Package (Alum. Rod) PSN F701597 (See Note #2) Includes:	AC	5H46-953		4		6		8		12
189	Connecting Rod Bolt (2) 5H46-1041	NSS									
NI	Lock Washer (2) 5H460-2041	AC									
NI	Plain Washer (2) AU02AA-242-020	PT									
	Connecting Rod (1) 5H46-1293	NSS									
	Dowel Pin (2) 7J1-6032-012	PT									
192	Seal End Bearing Washer	AC	5H40-1062	1	1	1	1	1	1		
193	Seal End Thrust Washer	AC	5H40-1072	1	1	1	1	1	1		
		AC	5H120-1072							1	1
194	Pump End Bearing Washer	AC	5H40-1082	1	1	1	1	1	1	1	1
195	Piston and Pin Assy. (Unassembled) Includes:	AC	5H40-482	4		6		8		12	
		AC	5H46-482		4		6		8		12
196	Piston (1)	NSS									
197	Piston Pin (1) 5H40-1051	AC									
198	Piston Pin Lock Ring (1) 5H40-3531-012	PT									
	Piston Rings (See Note #1)										
199	- Oil	NSS	5H40-1091	8	4	12	6	16	8	24	12
200	- Compression	NSS	5H40-1071	8		12		16		24	
	- Compression	NSS	5H46-1071		8		12		16		24

*NOTE: 1: Piston Rings are available in packages only.
For 5H40, 60, 80 and 120 Compressors, order 5H40-481 which includes:
(8) 5H40-1091 Oil Rings
(8) 5H40-1071 Compression Rings
For 5H46, 66, 86 and 126 Compressors, order 5H46-481 which includes:
(4) 5H40-1091 Oil Rings
(8) 5H46-1071 Compression Rings*

2: SSN F701597 Long Stroke Compressors (5H46, 66, 86 and 126) are built using Steel Rods as found in 5H40-103 Conn. Rod Pkg. When replacing individual rods in L.S. Compressors PSN F701597 Aluminum Conn. Rod Pkg. 5H46-953 should be used. Caution should be used that a mixture of Aluminum and Steel Rods are not used in the same compressor.

201	Oil Recovery Impeller	AC	5H120-1354							1	1
202	Headed Dowel Pin	AC	5H120-2191							1	1



COMPRESSOR/CONDENSING UNITS

5H
FREON

ITEM NO.	PART NAME	LDC	REPLACEMENT PART NUMBER	UNIT USAGE							
				5H							
				40	46	60	66	80	86	120	126

UNDERSIZE CRANKSHAFT AND BEARING GROUP

NI	.010" Undersize Crankshaft and Bearing Pkg.	NA	5H40-544	1									
		NA	5H60-544		1								
		NA	5H80-544					1					
		NA	5H120-544									1	
	Each Includes:												
NI	Crankshaft	(1) See Note #2	NSS										
NI	Connecting Rod Brg. Half	See Note #1											
	on 5H40	(8) 5H40-3612	NSS										
	on 5H60	(12) 5H40-3612	NSS										
	on 5H80	(16) 5H40-3612	NSS										
	on 5H120	(24) 5H40-3612	NSS										
NI	Seal End Main Bearing	(1) 5H40-3632	AC										
NI	Pump End Main Bearing	(1) 5H40-3652	AC										
NI	Center Bearing												
	on 5H80 only	(2) 5H80-3672	AC										
	on 5H120 only	(1) 5H80-3672	AC										
NI	Center Brg. (5H120 Only)	(1) 5H120-3672	AC										
NI	.020" Undersize Crankshaft and Bearing Pkg.	NA	5H40-554	1									
		NA	5H60-554		1								
		NA	5H80-554					1					
		NA	5H120-554									1	
	Each Includes:												
NI	Crankshaft	(1) See Note #3											
NI	Connecting Rod Brg. Half	See Note #1											
	on 5H40	(8) 5H40-3622	NSS										
	on 5H60	(12) 5H40-3622	NSS										
	on 5H80	(16) 5H40-3622	NSS										
	on 5H120	(24) 5H40-3622	NSS										
NI	Seal End Main Bearing	(1) 5H40-3642	AC										
NI	Pump End Main Bearing	(1) 5H40-3662	AC										
NI	Center Brg. (5H80 Only)	(2) 5H80-3682	AC										
NI	Center Bearing												
	(Top 5H120 Only)	(1) 5H120-3682	AC										
NI	Center Bearing												
	(Bottom 5H120 Only)	(1) 5H80-3682	AC										
	Bearings for .030" Undersize Crankshaft												
	Connecting Rod Bearing Half (See Notes 4&5)												
	on 5H40	(8) 5H40-1002-S3	NSS										
	on 5H60	(12) 5H40-1002-S3	NSS										
	on 5H80	(16) 5H40-1002-S3	NSS										
	on 5H120	(24) 5H40-1002-S3	NSS										
	Seal End Main Bearing	(1) 5H40-1012-S3	AC										
	Pump End Main Bearing	(1) 5H40-1022-S3	AC										
	Center Bearing												
	on 5H80 only	(2) 5H80-1242-S3	AC										
	on 5H120 only	(1) 5H80-1242-S3	AC										
		(1) 5H120-1242-S3	AC										

- NOTES: 1. Parts (5H40-3612 and 5H40-3622, Connecting Rod Bearings are available in packages only. For .010" Undersize order 5H40-461 which includes: (4) 5H40-3612 Bearing Halves. For .020" Undersize order 5H40-471 which includes: (4) 5H40-3622 Bearing Halves.
2. .010" Undersize is identified by an "A" stamped on Crankshaft.
3. .020" Undersize is identified by a "B" stamped on Crankshaft.
4. .030" Undersize is identified by a "30" stamped on Crankshaft.
5. Part 5H40-1002-S3, Connecting Rod Bearings are available in package only. Order 5H40660001 which includes: (4) 5H40-1002-S3 Bearing Halves



COMPRESSOR/CONDENSING UNITS

5H

FREON

ITEM NO.	PART NAME	LDC	REPLACEMENT PART NUMBER	UNIT USAGE							
				5H							
				40	46	60	66	80	86	120	126

VALVE PLATE GROUP

203	Valve Plate Package	AC	5H40-120A	2		3		4		6	
		AC	5H46-120A		2		3		4		6
	<i>NOTE: To identify package, inspect Valve Plate. "LS" will be stamped on edge of Valve Plate used in 5H46-120A.</i>										
	Includes:										
204	Valve Plate (1)	NSS									
205	Valve Plate Gasket (1) 5H40-1083-030	PT									
74	Cylinder Head Gasket (1) 5H40-1093-010	PT									
206	Suction Valve (2) 5H40-1142	AC									
207	Suction Valve Spring (12) 5H40-1791-012	PT									
NI	Valve Clip (For Assembling Only) (4) 5F20-2061	AC									
208	Lockwasher (6) 5H40-1481-012	PT									
209	Screw 5/16-24 x 1-1/4 (Guide) (6) ABO6BR-202-012	PT									
210	Discharge Valve Guide (2) 5H40-A552	AC									
	Includes:										
211	Lockplate (1) 5H40-1201	AC									
212	Guide (1) 5H40-1553	AC									
213	Discharge Valve (1) 5H40-1132	AC									
214	Discharge Valve Spring (6) 5H40-7322-012	PT									
215	Screw 5/16-24 x 1-1/4 (Lockplate to Guide) (3) ABO6BR-202-012	PT									
216	Dowel Pin 3/16" Dia. (2) AX11AR-128-020	PT									
217	Dowel Pin 1/4" Dia. (1) AX11AR-162-020	PT									
	Inner Seat (1) 5H40-1191	AC									
218	Capscrew (7/16-14 x 1-1/4) Plate to Crankcase	PT	AA06BR-262-012	4	4	6	6	8	8	12	12
219	Capscrew Gasket 7/16" (Not Used in Current Production)	PT	AU51YA-008-012	4	4	6	6	8	8	12	12

UNLOADER GROUP

220	Unloader Sleeve	AC	5H40-1752	3	3	4	4	6	6	8	8
221	Valve Lifter Spring	PT	5H40-2241-012	18	18	24	24	36	36	48	48
222	Valve Lifter Pin	AC	5H40-2231	18	18	24	24	36	36	48	48
223	Unloader Power Element Assembly	AC	5H40-163	3	3	4	4	6	6	8	8
	Includes:										
224	Unloader Cyl. Bracket (1) 5H40-1762	AC									
225	Unloader Cylinder Gasket (Bottom) (1) 5H40-1711-012	PT									
226	Unloader Cylinder (1) 5H40-1772	AC									
227	Unloader Piston (1) 5H40-1782	AC									
228	Unloader Piston Rod (1) 5H40-1731	AC									
229	Unloader Spring Retaining Washer (1) 5H40-1811	AC									
230	Unloader Spring (Inner) 3-19/32" Lg. (1) 5H40-1822	AC									
231	Unloader Spring (Middle) 3" Lg. (1) 5H40-2812	AC									
232	Unloader Spring (Outer) 2-3/32" Lg. (1) 5H40-1802	AC									
233	Unloader Cyl. Gskt (Top) (1) 5H40-1701-012	PT									



COMPRESSOR/CONDENSING UNITS

5H

FREON

ITEM NO.	PART NAME	LDC	REPLACEMENT PART NUMBER	UNIT USAGE							
				5H							
				40	46	60	66	80	86	120	126
UNLOADER GROUP (CONT'D.)											
223	Unloader Power Element Assy. (Cont'd.) Includes:										
234	Unloader Fork (1)-5-H--40--7312	AC									
235	Cyl. Cover Plate Assy. (1)-5-H--40--242	AC									
236	Lockwasher 5/16" (3)--AU--27AF-201	MP									
237	Capscrew 5/16-24 x 2-1/8 (3)--AB--06BF-574	MP									
238	Cotter Pin 1/16" x 3/8 (1)--AX--01AA-003	MP									
239	Plate Washer (1)-5-F--20--1301	MP									
240	Clevis Pin (1)-5-F--20--2571	AC									
241	Unloader Bracket Gasket	MP	-5-H--40--1451--	3	3	4	4	6	6	8	8
242	Socket Head Capscrew 5/16-24 x 1-1/4	MP	--AB--44AA-202--	6	6	8	8	12	12	16	16
243	Lockwasher 5/16	MP	--AU--61ML-201--	6	6	8	8	12	12	16	16
HAND HOLE COVER GROUP											
244	Hand Hole Cover and Sight Glass Assembly (1" Dia. Screw-In Type Sight Glass) Includes:	AC	-5-H--40---102--	1	1	1	1	1	1		
		AC	-5-H-120---102--							1	1
245	*ØSight Glass Package (1)-5-F--20---152 Includes:	AC									
246	Sight Glass (1)-5-F--20---781	NSS									
247	Sight Glass Gasket (1)-5-F--20--1631	MP									
	<i>NOTE: The 2-piece Sight Glass Package 5F20-152 replaces the 4-piece Screw-In type Sight Glass that has been used on some Hand Hole Covers.</i>										
	Old Style Hand Hole Cover used the following Bolt-On Type Sight Glass (1-1/2" Dia. Glass)										
248	Sight Glass (1)-5-H--40--1001	AC									
249	Inner Gasket (1)-5-H--40--1011	AC									
250	Sight Glass Clamping Gland (1)-5-H--40--1021	AC									
251	Outer Gasket (1)-5-H--40--1621	AC									
NI	Capscrew 5/16-18 x 5/8 (3)--AA--06BF-199	MP									
NI	Everlock Washer (3)--AA--27AR-201	MP									
252	Hand Hole Cover Gasket	MP		2	2	2	2	4	4	4	4
253	Hand Hole Cover Plain	NS	-5-H--40--1304--	1	1	1	1	3	3	2	2
254	Hand Hole Cover for Interconnection (May be used on any size if required.) Includes:	NA	-5-H--40---703							1	1
252	Hand Hole Cover Gasket (1) 5H40-1042-012	MP									
255	Capscrew 7/16-14 x 2-1/4	MP	--AA--06BR-266--	26	26	26	26	54	54	54	54
256	Capscrew Gasket 7/16 (Not Used on Current Production)	MP	--AU--51YA-008--	28	28	28	28	56	56	56	56
257	Oil Filter (External) (See Page 67.)		05HG-660---020--	1	1	1	1	1	1	1	1
NI	Half Union Elbow, Orifice	MP	--DD--40CA-051	1	1	1	1	1	1	1	1



COMPRESSOR/CONDENSING UNITS

5H
FREON

ITEM NO.	PART NAME	LDC	REPLACEMENT PART NUMBER	UNIT USAGE							
				5H							
				40	46	60	66	80	86	120	126
HAND HOLE COVER GROUP (CONT'D.)											
258	Oil Filter Bracket	AC	5H40-2832	1	1	1	1	1	1	1	1
259	Control Bracket Stud	AC	5H40-1781	4	4	4	4	4	4	2	2
NI	Elbow 1/4 x 1/4	PT	DD10CA-052-005	1	1	1	1	1	1	1	1
260	Pressure Control Bracket (A-B) (Robertshaw) (Robertshaw)	NA	5F40-1372	1	1	1		1		1	
		NS	5F40-4922					1		1	1
		AC	+*5H40-7232	1	1	1	1	1	1	1	1
261	Pressurestat High Side Low Side High Side Low Side	AC	HK02HA-012	1	1	1	1	1	1	1	1
		AC	HK02HB-012	1	1	1	1	1	1	1	1
		AC	+*HK02UA-300	1	1	1	1	1	1	1	1
		AC	+*HK02UB-050	1	1	1	1	1	1	1	1
262	Pressurestat Tube Clip	AC	5F20-1501	2	2	2	2	2	2	2	
NI	Enclosure, Pressurestat (Robertshaw)	AC	HK09UZ-012					1		1	1
	+* NOTE: The new Robertshaw Bracket (5H40-7232) is required when replacing any old style Pressurestat (Dual or HK04UN-500 Type). When replacing a HK04UN-500 Pressurestat, both the high and low plus Bracket will have to be replaced.										
NI	Oil Filter Package (Old Type)	NA	5H40-963	1	1	1	1	1	1	1	
	Includes:	AP	5H40-A274	1	1	1	1	1	1	1	
	Oil Filter (1) KH18BV-003	AC									
	Mounting Bracket (1) 5H40-2832	AC									
	Filter Inlet Tube Assy (Top)										
	Used on 5H60-66 (1) 5H60-166	NA									
	Filter Inlet Tube Assy (Top)										
	Used on 5H40,46,80,86 (1) 5H40-166	AC									
	Filter Outlet Tube Assy (1) 5H40-176	AC									
	Angle Valve 1/4 FL x 1/4 MPT (1) EP23LC-090	AC									
	Half Union Elbow w/Orifice										
	1/4 FL x 1/4 MPT (1) DD40CA-051-005	PT									
	Double Branch Angle Valve (1) EP32TA-150	AC									
	Half Union Elbow										
	1/4 FL x 1/4 MPT (1) DD10CA-052-005	PT									
	Adapter (1) 5F20-1311	AC									
	Rd. Hd. Machine Screw										
	1/4-20 x 1-3/4 (1) AC15AA-174	NA									
	1/4-20 Hex Nut (1) AT39AA-171-020	PT									
	3/8 Lockwasher (2) AU11AA-241	NA									
	3/8-16 Hex Nut (2) AT39AA-241	AC									
	Control Bracket Studs (2) 5H40-1781	AC									
	7/16 Capscrew Gaskets (2) AU51YA-008-012	PT									
5/8 Adapter Gasket (1) AU51YA-011-012	PT										
Pressure Gauge (2) KM01BC-201	NA										
Flare Gasket (1) DD24FA-051	NA										
Washer 3/8 (2) AU01AA-241	NA										
Elbow 1/4 FFL x 1/4 MFL (1) DD12CA-051	NA										
Fitting 1/4 FFL x 1/4 FPT (1) 5H40-5872	NA										